

Future Proofing Access Networks Through Wireless/Wireline Convergence

A Technical Paper prepared for SCTE/ISBE by

Martin J. Glapa

Partner and Bell Labs Fellow
Nokia, Bell Labs Consulting
366 Monte Vista Rd.
Golden, CO. 80401
303-517-1273

Martin.Glapa@bell-labs-consulting.com

Hungkei (Keith) Chow

Head of Department
Access Platform Research, Fixed Network Lab, Nokia Bell Labs
600 Mountain Ave., New Providence, NJ 07974
908-582-7685
Hungkei.Chow@nokia.com

Werner Coomans

Member of Technical Staff
Fixed Networks Lab, Nokia Bell Labs
Copernicuslaan 50, 2018 Antwerp
werner.coomans@nokia.com

R. J. Vale

Leader of Strategic Techno-Economic Analysis – Future Networks R&D
Nokia, Bell Labs Consulting
972-477-8674
Rj.vale@bell-labs-consulting.com

Enrique Hernandez-Valencia

Partner and Bell Labs Fellow
Nokia, Bell Labs Consulting
600 Mountain Avenue, Room 7E-318
Murray Hill, New Jersey, 07974
908-582-3144

Table of Contents

Title	Page Number
Introduction	3
1. Future Access Network Vision	3
1.1. Deep Fiber Access Evolution	4
1.2. High-Capacity and Low-Latency Cable Access	5
1.3. SDN/NFV Enablement	7
1.4. Convergence	8
2. A Common Access Network Convergence Platform	9
2.1. Future Remote (FR)	10
2.2. Universal PHY System-on-Chip	11
3. Use Case Example	13
3.1. Dynamic capacity	13
3.2. Economics / Comparative TCO analysis	13
Conclusion	14
Abbreviations	15
Bibliography & References	16

List of Figures

Title	Page Number
Figure 1 - Pillars of Future Access Networks	4
Figure 2 - Deep Fiber Access Networks	5
Figure 3 - Evolution to High Capacity Low Latency Networks	6
Figure 4 - New Applications Redefine Network Capacity and Latency Requirements	7
Figure 5 - SDN/NFV Enablement	8
Figure 6 - Access Network Convergence Characteristics	8
Figure 7 - Future Converged Access Network Architecture	10
Figure 8 - Simplified Functional Block Diagram of a Future Remote	10
Figure 9 - Digital Baseband Processing Pipeline for FDX DOCSIS and mmWave Wireless	11
Figure 10 - Generic Universal PHY SoC Architecture	12
Figure 11 - Dynamic capacity use case	13
Figure 12 - Economic benefits of convergence	14
Figure 13 - Economic benefits details	14

Introduction

Multi-Gbps wireless and wireline services are pushing fiber deployments deeper into the outside plant and setting the stage for converged access networks. On the cable front, Distributed Access Architectures (DAA) using higher modulation orders and symmetrical Full Duplex (FDX) DOCSIS® will leverage existing drop coax, but will require MSOs to upgrade their HFC access networks to an N+0 deep-fiber architecture. In the special cases of MSO MDU (multi-dwelling unit) copper access through Fiber-to-the Distribution Point (FTTdp), copper assets will be leveraged using next-generation DSL technologies such as G.fast or G.mgfast. On the wireless front, licensed and unlicensed spectrum services (i.e., 5G, LTE, MulteFire, CBRS, etc.) will require small cells located close to the end-user, and require fiber all the way to the radio headend for backhaul. These deep-fiber-based architectures will all require that fiber be brought in very close-proximity to the end-users, creating an ideal convergence point to integrate short-reach distance-sensitive wireless and wireline technologies into a single converged access platform. Such a converged access platform will: 1) offer seamless service and content movement across any form of available access media, 2) provide dynamic resource shifting across multiple media access forms active at any time, 3) enable dynamic slicing, adaptation and coordination of network resources under the control of centralized virtual network orchestration in edge cloud/cable hub data centers, 4) be optimized in cost, space and power consumption, and 5) enable operational savings by reusing a converged infrastructure.

Technical, architectural and economic studies and insights on how MSOs can leverage their deep-fiber DAA/FDX DOCSIS networks to become leaders in deploying cost-effective future-proof converged wireline/wireless access networks and services, and become leaders in the deployment of mmWave technologies, are presented in this paper.

1. Future Access Network Vision

The future of access networks is defined by four major pillars that result in both architectural and technological shifts away from current access network design paradigms. While these pillars apply to all types of access networks, the focus in this paper is on cable and fixed wireless access networks, and their convergence on a common platform. Figure 1 illustrates these pillars which are:

1. Deep fiber – resulting in a future-proof network (to enable multiple MSO deployment options).
2. High capacity, low latency - enabling a hyper-scalable (subscriber and bandwidth tier scaling), hyper-capacity (symmetrical multi-Gbps bandwidth), hyper-performance (millisecond delays) network to serve a variety of MSO subscribers and bandwidth needs.
3. Convergence - of fixed wireless access networks on a common access platform – to enable hyper-flexible (dynamic support of multiple access mechanisms) based on need, demand, and competition.
4. SDN/NFV enablement – resulting in a programmable virtualized network.

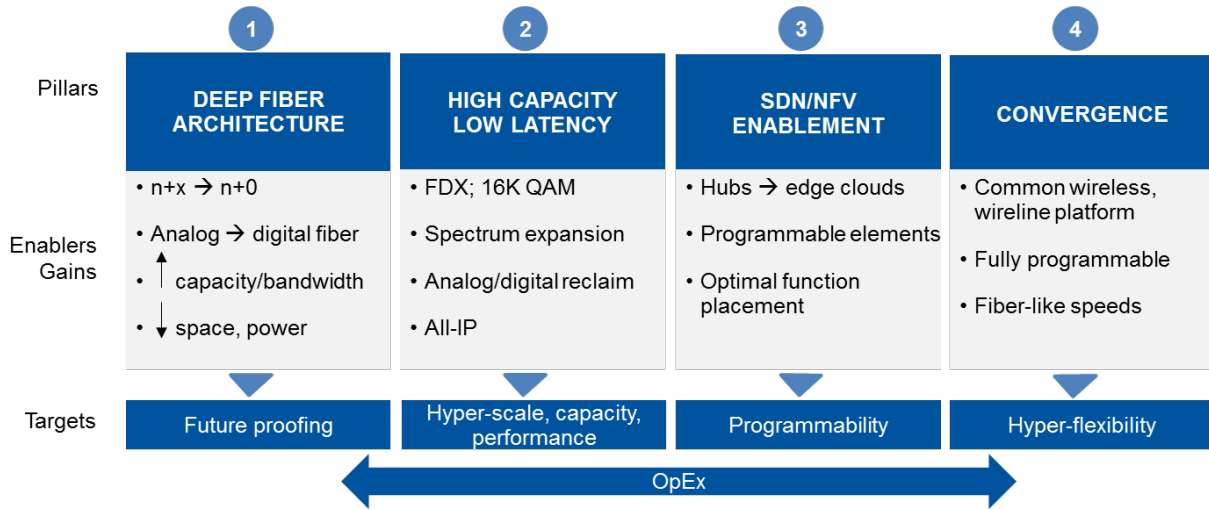

Figure 1 - Pillars of Future Access Networks

The following sections describe how these pillars enable future proofing of network investments through a common converged wireless/wireline access platform.

1.1. Deep Fiber Access Evolution

Access network architectures of all types: coax, copper, and fiber, have evolved and will continue to evolve dramatically as access speeds continue to increase. Generally, achieving high signal rates on access networks is distance-limited due to physical propagation characteristics. The use of higher spectrum bands that goes with the higher signal rate requires shortening the distance between the access node and the end user. In many deployment scenarios, fiber is brought to within 50m to 100m of end-users to achieve such multi-Gbps rates.

Cable access networks have been progressively pushing fiber deeper toward end users for many years. Early days of Hybrid-Fiber Coax (HFC) deployments used for video distribution saw the number of Households Passed per fiber node (HHP) in the several thousands, with many amplifiers on the coax between the fiber node location and the last user. As the need for voice and data services were added over time, and as the demand for high-speed data has continued to increase, fiber node serving areas have been made smaller by means of pushing fiber nodes (and hence fiber) closer to the end users. Thus, the number of subscribers served per fiber node have been reduced while providing greater bandwidth to users. In this process the average number of amplifiers on the coax cable between the fiber node and the last user has been reduced from $N+6$ (fiber node + the number of amplifiers) to $N+x$, ($x=5,4,3,2$) in many deployments. These architectures enable 1Gbps, and potentially even higher, downstream service access rates. Deep-fiber cable architectures, including deployment of Remote-MAC/PHY (RMD) and Remote-PHY (RPD) equipment at $N+x$ locations (typically where $x=2$ or 0), are referred to as Distributed Access Architectures (DAA). The introduction of Full Duplex (FDX) DOCSIS® will require an $N+0$ (i.e. fiber node deployed at the last amplifier location) architecture as FDX signals cannot be passed through existing amplifiers. In this point-to-multipoint architecture, fiber will be brought to within approximately 100m to 300m of end users, on average, and a maximum of several tens of users will be served from each node. Using 1.2 GHz of spectrum, FDX can theoretically provide 10Gbps symmetrical bandwidth. However, FDX DOCSIS will initially only target FDX operation over a reduced spectrum, enabling multi-gigabit upstream service rates. A longer-term alternative is to drive fiber all the way to the last tap,

bringing fiber to within tens of meters of about four to six users, and exploit signal bandwidths larger than 1.2 GHz.

In traditional twisted pair copper access, there is a long history of continuously increasing the data rates by increasing the fiber penetration depth. This evolution is continuing today with the advent of the G.fast standard, and the recent start of a new G.mgfast ITU-T project, which stands for multi-gigabit capable G.fast.

A similar evolution is occurring in wireless access networks. Macro cells, typically with a coverage radius of a few Km in a dense urban environment (depending on many factors such as radio frequency propagation, traffic, population density, etc.), are being supplemented with small cells with a much shorter radius. For example, 4G small cells may have a 100-300m radius, and 5G mmWave fixed wireless access will be limited to about 100m. These small cells will support peak rates of 1Gbps and sustained rates of up to 100Mbps¹. Deep fiber deployment will be required to backhaul the end-user traffic of such Radio Access Networks (RANs) to the wireless core sites.

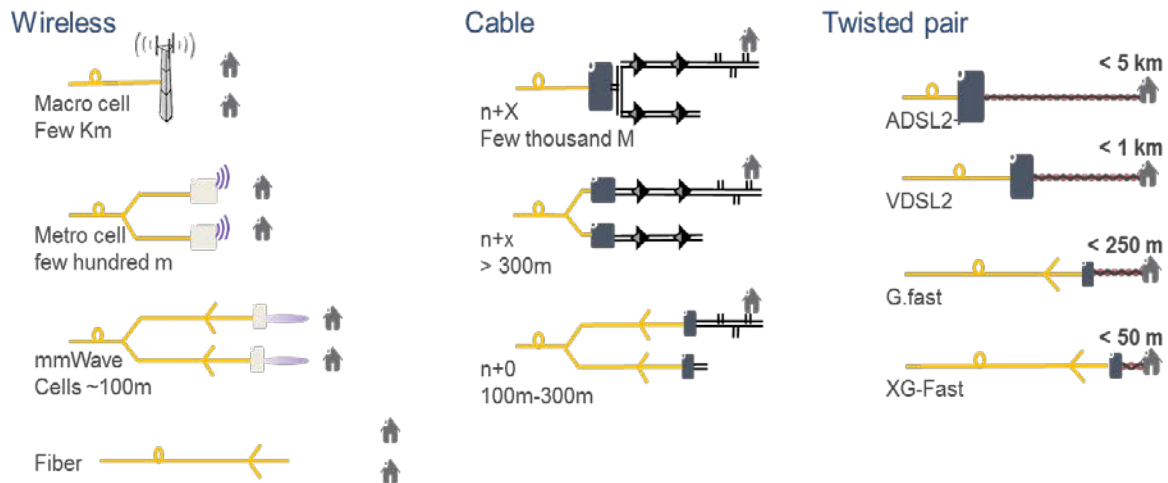

Figure 2 - Deep Fiber Access Networks

Figure 2 illustrates the migration to deep fiber in cable and wireless networks. All-of-the access architectures discussed, have at this point, one thing in common, fiber to within about 100m-300m of the end user. This enables an ideal convergence and colocation point from which to serve both fixed wireline and fixed wireless customers, and to enable future-proof networks.

1.2. High-Capacity and Low-Latency Cable Access

In parallel with deep fiber deployment, cable access networks are evolving along spatial, spectral efficiency, and signal spectrum dimensions as illustrated in Figure 3.

¹ Peak and sustained bandwidths are dependent on many factors such as the number of simultaneous users, the distance from a user to a wireless access point, and many others.

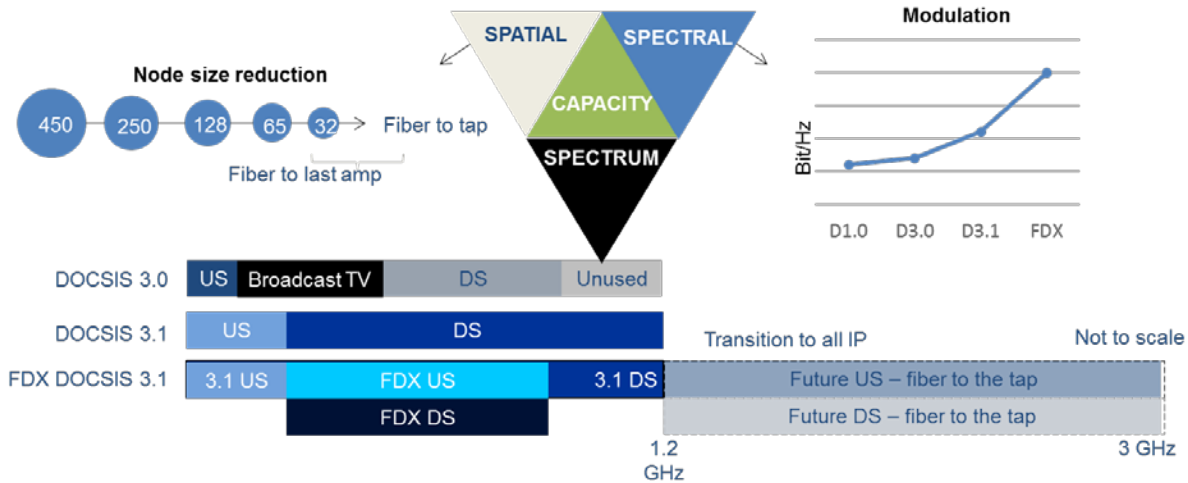

Figure 3 - Evolution to High Capacity Low Latency Networks

Spatial evolution is the progression of node, amplifier and service area reduction in the N+x architecture, facilitated by deep fiber deployment, as discussed in Section 1.1. Many MSOs are also evolving their outside plant spectrum to 1GHz or higher, enabling additional bandwidth to be used to support new high-bandwidth services. Future Fiber-to-the-Tap deployments may enable exploitation of broader signal spectrums on the order of a couple of GHz. In addition, spectral efficiency improvements over time, building up to DOCSIS 3.1 and FDX DOCSIS, will enable higher utilization of the available spectrum. Finally, the shift of analog towards all-IP further contributes to increasing the utilization of available spectrum resources.

DAA enables significant power and space savings at the hub or headend sites. These savings will be very useful for future MSO growth as it lowers the barrier to house general purpose servers and create edge clouds. Edge clouds are needed to support the new high-bandwidth and low-latency applications such as connected cars, augmented/virtual reality-based applications, and even virtual access nodes (such as virtual RANs). The longer reach provided by digital optics in DAA, combined with edge clouds, also enables consolidation of hub sites, saving further operational costs. Service-related functions can also be virtualized and deployed at these edge clouds locations, as needed, to derive additional benefits of increased performance, service agility, CapEx and OpEx reductions (over comparable monolithic approaches). Clearly, there is even greater opportunity to share the costs of facility, compute/storage resources and administration/management staff when wireless and wireline access networks' components are integrated (converged) at the same site, whether it is at a hub or a headend. Such convergence of access network components opens the opportunity to share services components such as firewalls, CDNs, DVRs, etc. across wireline as well as wireless customers using the same underlying hardware and software resources, and the same operational platforms and processes.

By bringing services closer to users, edge clouds not only enable better quality of experience for latency-sensitive services, but also permit elastic capacity scaling and help reduce transport network costs by avoiding backhauling user traffic to core locations. This is consistent with trends from leading Cloud Service Providers that are also collocating many of their service enabling capabilities closer to customers. Figure 4 shows examples of classes of applications requiring different low latency.

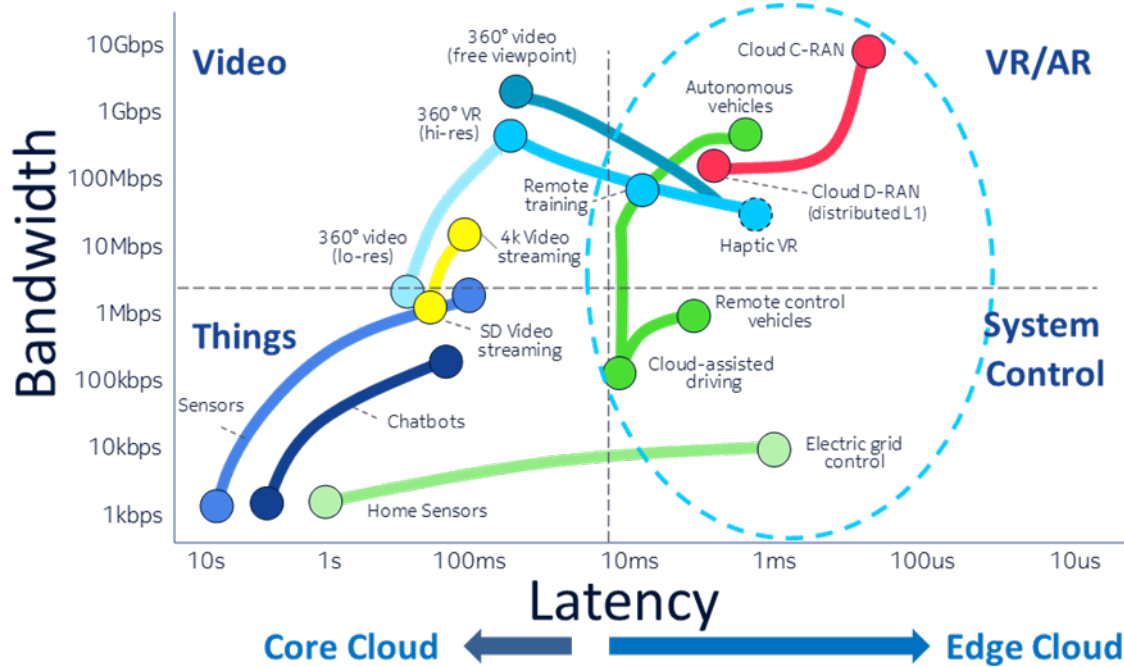

Figure 4 - New Applications Redefine Network Capacity and Latency Requirements

Hyper-scalable, hyper-capacity, hyper-performance networks thus become possible.

1.3. SDN/NFV Enablement

An SDN-oriented framework to control resources and automate the management of such converged networks is critical to achieve the envisioned economic benefits. A hierarchy of SDN controllers will be needed to disaggregate the management of the end-to-end services from the network resources across the multiple network domains (access, transport, hubs/headends and data centers). This programmability enables independent dynamic adaptations in the network resources according-to changing traffic patterns, chaining of new service functions on-demand and agility to instantiate, or develop, new revenue-generating services. Such modular abstraction of the network capabilities is needed to support a massively scalable and agile network architecture and operations that can handle a 100x expected increase in the number of service sessions from IoT and other digital home and enterprise applications.

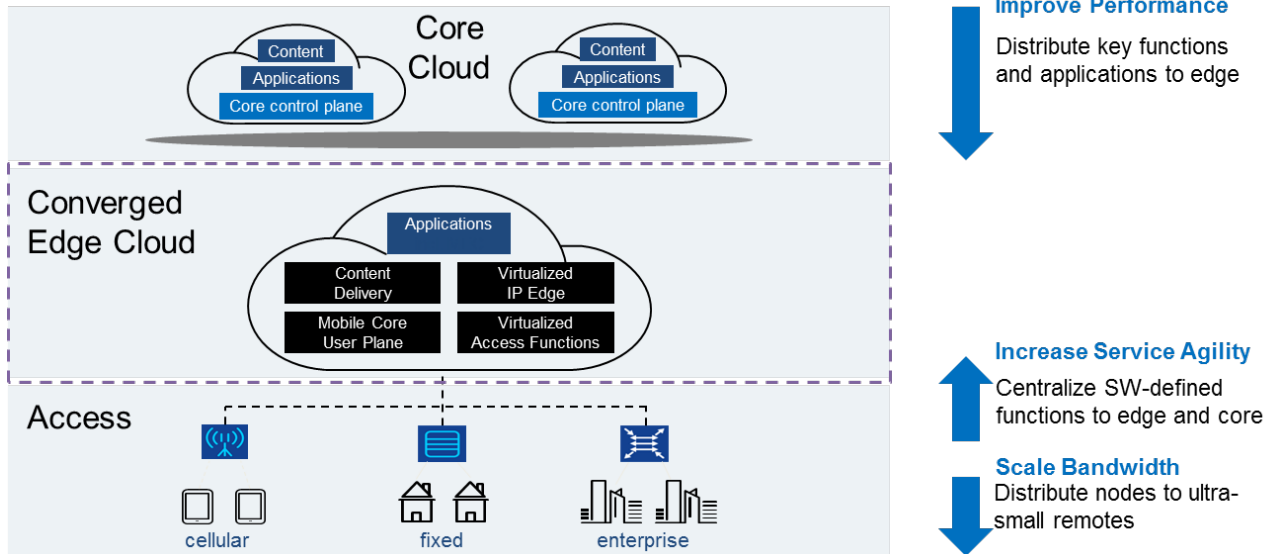

Figure 5 - SDN/NFV Enablement

1.4. Convergence

As described earlier, future high-speed wireless and wireline access technologies will be located within 100m-300m of end-users. As such, other access network characteristics, such as common backhaul, and co-resident physical layer (PHY) and media access control (MAC) layer further enable the development of a convergence access platform. Figure 4 illustrates these and other characteristics of future access nodes.

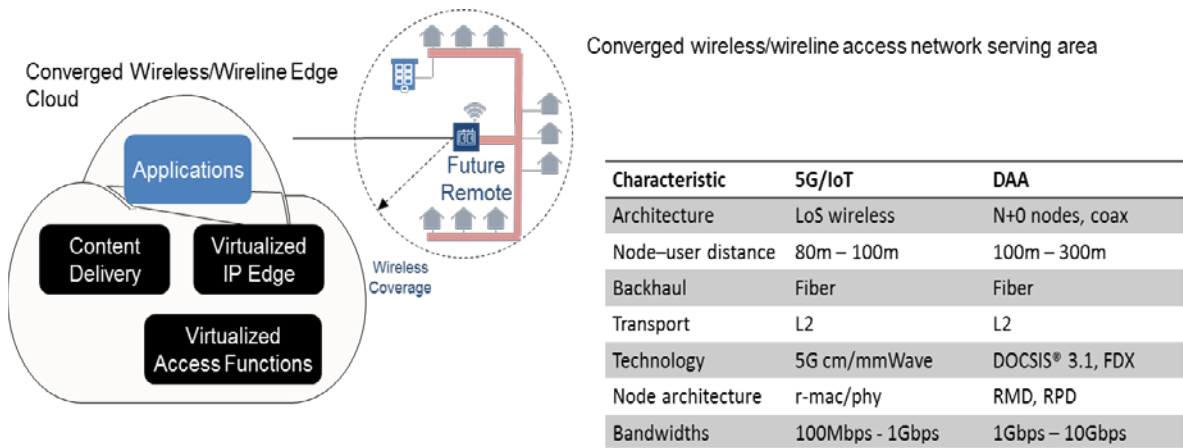

Figure 6 - Access Network Convergence Characteristics

Collocating common functions enables flexible and cost-effective deployment options. Variations in geography, morphologies and competition will dictate the specific configuration needs. A programmable converged access platform will offer flexible deployment options to meet such diverse needs. Longer

term, as wireless traffic is projected to grow at a faster pace than native wireline traffic, the platform can be reprogrammed to meet shifting consumer needs. Near term, as wireless and wireline usage patterns shift by time of day (refer to the use case example in Section 3), platform resources can be dynamically allocated to flexibly accommodate these needs. The next section discusses the technical details.

2. A Common Access Network Convergence Platform

The advent of NFV and SDN mentioned in Section 1.3 has given rise to the disaggregation of functionality that typically resided in bespoke hardware and software platforms. This approach, which also decouples hardware and software development, can be used to optimize the scaling and performance of each individual network function, thereby improving the overall performance of the network in various scenarios. The next step beyond NFV and SDN is to make the underlying hardware platform programmable so that it can be reconfigured and reused for multiple purposes. We have evaluated the potential for such a solution in the access network that is not only programmable to support a single technology dimension, but also across multiple key technology dimensions, e.g., wireline (Cable and Telco) and wireless (Cellular and Wi-Fi).

The anticipated future converged access network architecture is shown in Figure 6. In this architecture, a pool of common off-the-shelf computing and storage resources located at the future edge cloud hub can be configured and programmed to act as any combination of access technologies. Some common ones are shown as examples in Figure 6. More importantly, such a split/remote network architecture is already foreseen in the telecom service provider space as FTTN (Fiber-to-the-Node) and FTTdp (Fiber-to-the-distribution point), in the wireless service provider space as vRAN (virtual Radio Access Network) and in the MSO space as vCCAP with Remote-MAC/PHY. Such a converged edge cloud implements various Layer-2 and above networking functions as well as control and management interfaces.

Another degree of convergence in this architecture is the underlying feeder/interconnection network. Passive Optical Networking (PON) is becoming a technology of choice given its low equipment cost and flexibility in fiber distribution topology. PON has seen a significant increase in access capacity, for example, the evolution from EPON or GPON (1Gbps line rate) to 10G-EPON or XG-PON (10Gbps line rate). Recently, both the ITU-T and IEEE have begun the specification of higher data rate PON, noticeably as XGS-PON, NG-PON2 and 25G/100G TWDM PON.

Yet another less obvious degree of convergence is in the remote nodes, depicted as Future Remotes (FRs) in Figure 6, which form the basis of the future converged access solution. The FR implements the Layer-1 (physical layer) function of the supported access technologies. Operating as a combined wireless and wireline remote node in any combination, the FR can offer simultaneous converged access services that leverage both wireline and wireless connectivity to home/enterprise subscribers at the same time. Such an approach will provide better user experience that can be delivered at any point in time, using all available access resources in concert. Furthermore, given the common functional blocks in the PHY layers of future wireline and wireless technologies, economic benefits can be achieved by system vendors, chipset vendors and operators because of the multi-purpose usability of both these functional blocks and the resulting systems.

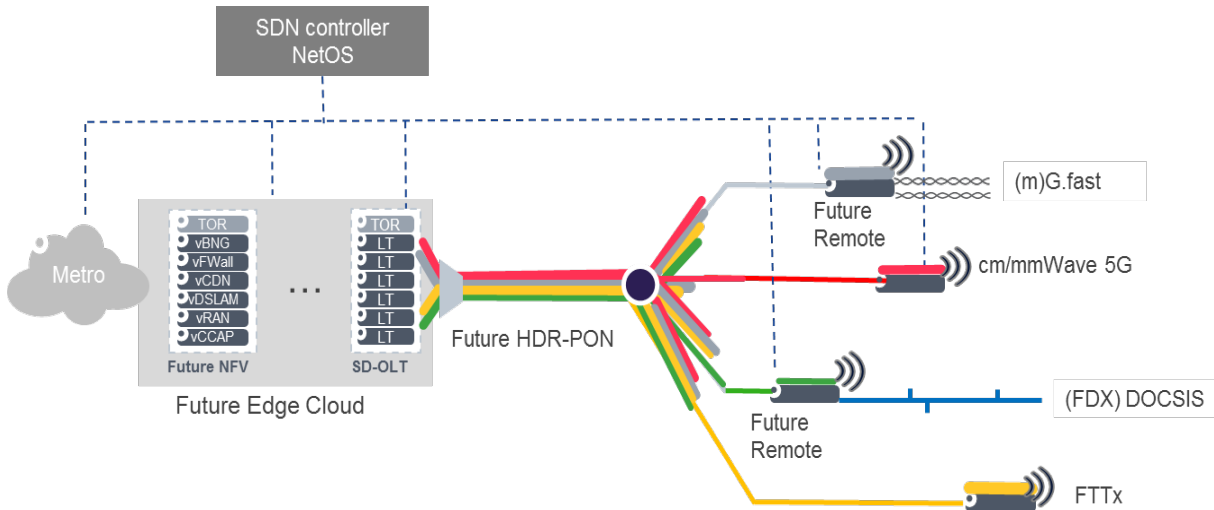

Figure 7 - Future Converged Access Network Architecture

2.1. Future Remote (FR)

Figure 7 shows a simplified block diagram of a FR node. On the subscriber line side, a FR is equipped with various analog front-end (AFE) modules. An AFE module implements a set of typical analog functions such as power amplification, RF mixing and filtering for a particular-application. Each supported access technology will have a corresponding AFE module that can be built as a pluggable module to suit the specific deployment scenario. Beside the AFE modules, the core of a FR is a universal PHY System-on-Chip (uPHY-SoC) which is realized as a programmable and reconfigurable ASIC. A uPHY-SoC implements the network side interface, e.g., a PON Optical Network Termination (ONT) or an Ethernet interface, a variety of digital baseband physical layer signal processing functions and/or MAC protocols. The operations, administration and management (OAM) as well as control functions of a FR, are performed over the SDN control and management interface.

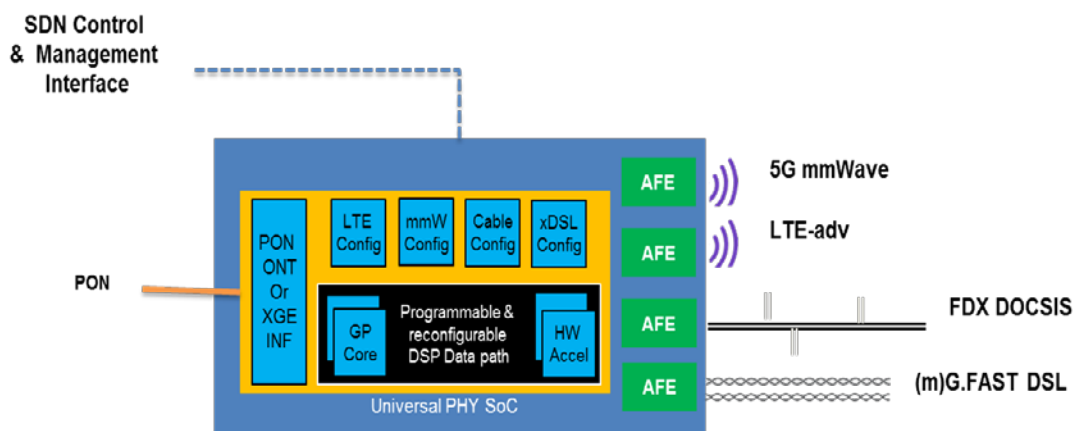

Figure 8 - Simplified Functional Block Diagram of a Future Remote

The future remote is in proof-of-concept stage and has been demonstrated by Bell Labs.

2.2. Universal PHY System-on-Chip

To realize the uPHY-SoC, we consider the digital baseband signal processing pipelines for all target access applications, such as the ones shown in **Error! Reference source not found.** The design objective of the uPHY-SoC is to achieve flexibility through programmability and reconfigurability, while maintaining the target throughput and efficiency, so that any combination of access technologies can be realized on a single uPHY-SoC. Even though the exact implementation of a particular-processing function may vary, our studies have shown that certain processing functions are better suited to be realized by either a general-purpose instruction processor (GPP) core, an array signal processor (ASP) or a specific function hardware accelerator (SFA). As indicated in 9, for example, the (I)FFT function, MIMO precoder function or pre-distortion filter function can be realized efficiently in an array signal processor structure, or more generally a Single-Instruction Stream-Multiple-Data stream (SIMD) processor structure, because of their regular and parallelizable data and instruction structure. Forward Error Correction (FEC) functions such as LDPC, turbo and Trellis/Viterbi code, however, are more suitable to be implemented as a reconfigurable special FEC hardware accelerator, given the massive internal connectivity of its signal flow. Other functions, such as scheduler, channel estimator and/or protocol processor, are good candidates for GPP cores, because of their irregular data and instruction flow implementation.

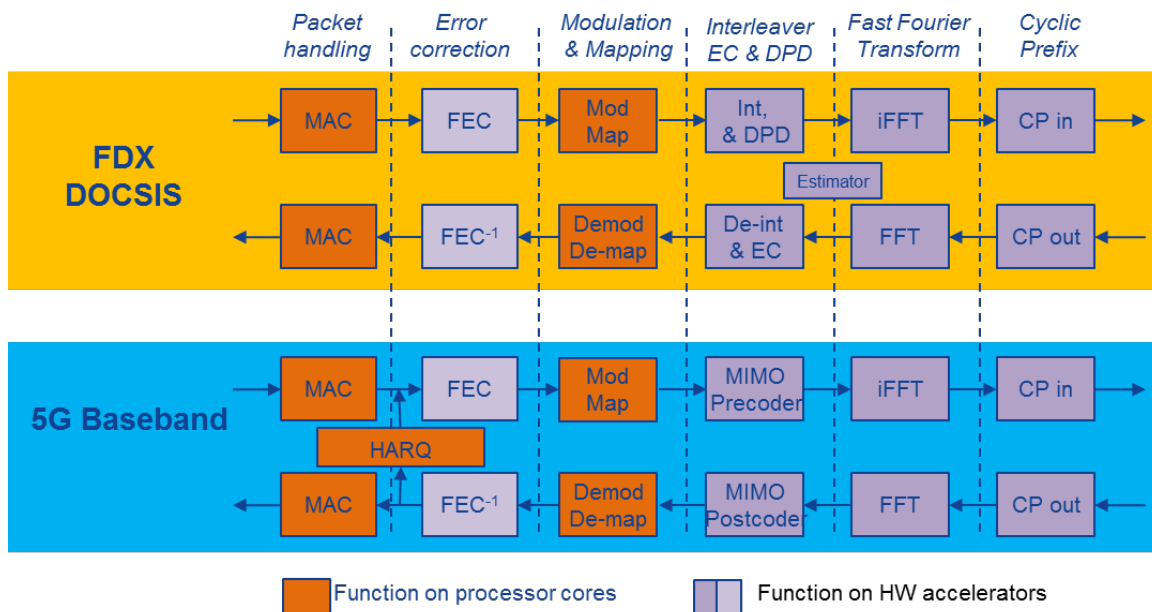

Figure 9 - Digital Baseband Processing Pipeline for FDX DOCSIS and mmWave Wireless

Given a mix of access applications under a target deployment scenario, one can determine the number of GPP cores, ASPs and SFA units required in a uPHY-SoC to support such a use case. Figure 9 illustrates the internal architecture of a uPHY-SoC. Various processing elements, GPP core, ASP cores and SFA units are connected on a configurable interconnection fabric. Even though **Error! Reference source not**

found. depicts a single interconnect fabric, actual implementation may be split into several dedicated fabrics with different throughputs and dimensions. On-chip SRAM may also be placed tightly-coupled with a certain set of processing elements or be placed as a shared memory pool. The high-speed input/output interfaces are typically being used to realize the network side interfaces, while the subscriber-side I/Os are connected directly via the DAC or ADC interfaces.

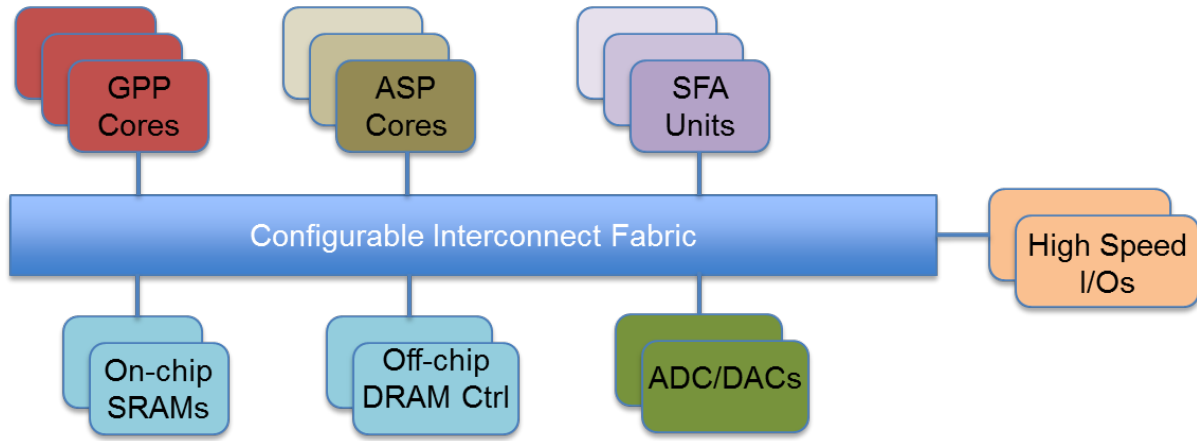

Figure 10 - Generic Universal PHY SoC Architecture

3. Use Case Example

3.1. Dynamic capacity

This use case represents typical user behavior pattern in terms of bandwidth consumption by access type varying by time-of-day. Refer to Figure 11. The use case assumes that the converged access platform supports both FDX DOCSIS and 5G fixed wireless access. By using a common platform and dynamically allocating capacity across the two networks, a converged operator can optimize fixed wireline and fixed wireless access deployment cost and provide flexibility to deal with dynamically changing traffic patterns.

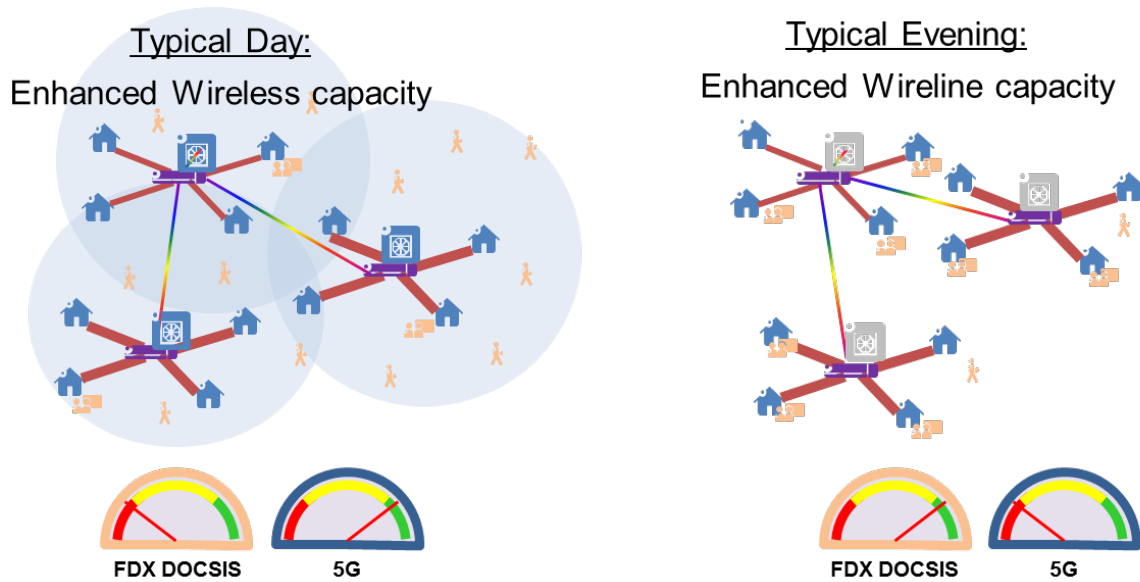

Figure 11 - Dynamic capacity use case

The left side of the figure illustrates that the primary day-time use is fixed wireless or nomadic access, while the right side of the figure illustrates the evening shift to primary wireline use of FDX DOCSIS as consumers settle in front of their PCs and TVs. The authentication for nomadic usage could happen through the standard mobile infrastructure enabling nomadic users to migrate to a mobile network when they move out of range. As an example, users at a bus station on a nomadic 5G fixed wireless connection switch over to mobile network as their bus moves out of range.

3.2. Economics / Comparative TCO analysis

A detailed total cost of ownership (TCO) analysis was performed to compare deployment models with discrete wireline and wireless systems against models using a converged system housing both wireline and wireless hardware. These were designed to provide dynamic capacity coverage as described in section 3.1 in three different morphologies – urban, suburban and dense urban. The wireless systems coverage was line-of-sight (LOS) with nomadic application. The results indicate that collocating wireless and wireline functions on the same converged access platform enables significant CapEx and OpEx savings over building discrete wireless and wireline access networks. Benefits are derived primarily from shared site acquisition, common fiber backhaul, powering, real estate and maintenance.

Dynamic wireline/wireless capacity use case

- Platform serves fixed wireline and nomadic 5G wireless users
- Day-time usage primarily nomadic wireless evening usage primarily 5G wireline
- FR resources dynamically shift between wireless and wireline service needs
- Up to 40% savings vs. building traditional-discrete wireline, wireless access networks

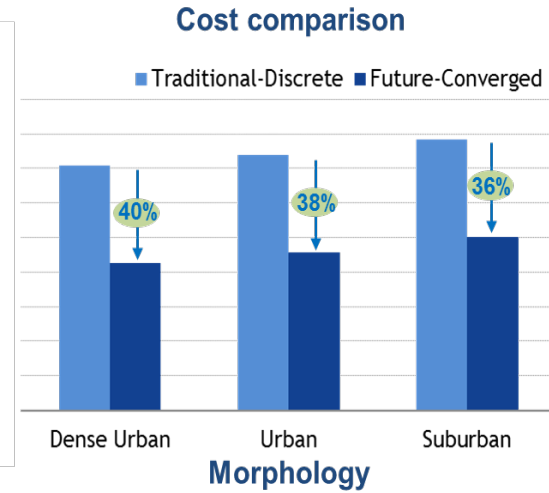

Figure 12 - Economic benefits of convergence

Figure 12 illustrates TCO savings of up to 40% over discrete networks in dense urban environments. Figure 13 illustrates the CapEx and OpEx savings details for the dense urban morphology.

TCO savings derived from:

- Site development: survey, acquisition, backhaul, power, enclosure
- Deployment: RF/network design, engineering optimization, install & commission, testing & integration, project management
- Network electronics: common baseband processors and Digital Signal Processors (DSPs)
- OpEx: network trouble management, preventive maintenance, RF performance optimization, capacity management, power

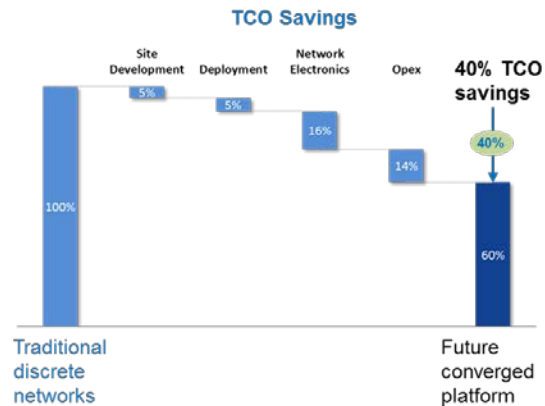

Figure 13 - Economic benefits details

The cost model is based on a converged network electronics when possible (e.g., uPHY-SoC, GPP etc.) that is shared between 5G fixed wireless and FDX systems. This architecture, in turn allows sharing many other common components such as power supply and mechanical systems on the same physical platform. Since both the platforms are contained in the same physical unit, it also results in considerable savings in site development, installation and operational expenses.

Conclusion

The future of access networks is defined by four major pillars that result in both architectural and technological shifts away from current access network design paradigms. These pillars are:

1. Deep fiber
2. High capacity, low latency
3. SDN/NFV enablement
4. Convergence

Deep fiber will bring fiber to within a few hundred meters of end-users. High capacity and low latency networks – enabled by deep fiber and the move to edge clouds, will enable MSOs to offer new applications. SDN/NFV will enable highly programmable MSO networks. Convergence of wireless and wireline technologies will be done at deep fiber locations, within a few hundred meters of end-users, on a common programmable access platform, and leverage the programmability of SDN/NFV. Such a platform is in the proof of concept stage at Bell Labs. Our studies have shown that up to 40% TCO savings can be achieved through the deployment of a converged multi-access (wireline and wireless) future remote platform over building discrete wireless and wireline access networks.

Abbreviations

ADC	analog digital conversion
AFE	analog front end
ASIC	application specific integrated circuit
ASP	array signal processor
Capex	capital expenditures
CBRS	citizens broadband radio service
CDN	content delivery network
DAA	distributed access architecture
DAC	digital analog conversion
DSL	digital subscriber line
DVR	digital video recorder
HFC	hybrid fiber-coax
EPON	ethernet passive optical network
FDX	full duplex
FEC	forward error correction
FFT	fast Fourier transform
FTTdp	fiber to the distribution point
FTTN	fiber to the node
FR	future remote
HHP	households passed
Gbps	gigabits
GHz	giga-hertz
GPON	gigabit passive optical network
GPP	general purpose processor
ISBE	International Society of Broadband Experts
I/O	input/output
IoT	Internet of Things
L1	layer 1
LDPC	Low density parity check
MAC	media access control (layer)

MDU	multi-dwelling unit
MIMO	multiple input, multiple output
MSO	multi-system operator
NFV	network function virtualization
OAM	operations, administration, management
PHY	physical (layer)
PON	passive optical network
RAN	radio access network
RMD	remote mac device
RPD	remote phy device
SCTE	Society of Cable Telecommunications Engineers
SDN	software defined networks
SFA	specific function hardware accelerator
SIMD	single-instruction stream-multiple-data stream
SoC	system on a chip
vCCAP	virtual common converged access platform
vCDN	virtual content delivery network
vRAN	virtual radio access network

Bibliography & References

The Future X Network A Bell Labs Perspective Book
 Version Date: 20150910