

# A COMPARISON OF CENTRALIZED VS. DISTRIBUTED ACCESS ARCHITECTURES FOR PON

Michael Emmendorfer and Sebnem ZorluOzer  
ARRIS

## *Abstract*

*This paper will define and compare two classes of access architectures that will emerge this decade for Passive Optical Network (PON). These two classes of access architecture may be referred to as centralized access architecture (CAA) and distributed access architecture (DAA) for PON. The CAA and DAA analysis is well underway for DOCSIS, but 10G EPON may be architected in a similar manner, in terms of splitting the PON access system components between the facility and a remote location, or placing all of the network device functions in a remote location. The DOCSIS use of distributed access architecture can place the MAC and PHY or just the PHY layer in the remote device, such as a node, cabinet, or multiple dwelling unit (MDU) location. The DAA for PON places both the MAC and PHY layers in the remote device. The DAA for PON defines how much of the upper layer functions are placed in the remote device and how much if any of the PON systems remain in the provider facility.*

*The optical line terminal (OLT) has evolved from a simple layer 2 device into some systems supporting higher layer networking functions, including advanced layer 2, layer 3 routing, and Multiprotocol Label Switching (MPLS). In addition, the cable industry defined a software mediation layer subsystem for Ethernet PON (EPON) and 10G EPON that enabled them to leverage their existing provisioning, network management, and network accounting systems used for their DOCSIS network to be used for EPON, this effort was the basis of CableLabs DOCSIS Provisioning of EPON (DPoE) standards.*

*The DPoE specifications defined advanced routing, switching, optical line terminal (OLT), and mediation layer subsystems to be part of a DPoE system. The DPoE system refers to the set of subsystems within the hub site that provides the functions necessary to meet the DPoE specification requirements [CableLabs]. This paper defines and examines next generation DPoE systems, which functions may not reside completely at a hub site, but rather can be in the cloud, hub site, and/or node locations. The next generation DPoE Systems will include additional features to facility based CAA DPoE systems and DAA DPoE systems.*

*The use of centralized access architecture (CAA) retains the MAC and PHY layer functions of the OLT subsystem in the headend or hub location. This paper will examine several current centralized access architectures for OLT subsystems. This paper will also propose the adoption of multiple wavelength technologies for 10G EPON DPoE systems. Three types of CAA DPoE systems will be examined in this paper.*

*The distributed access architecture (DAA) for PON began in the early 2000's with the placement of the entire OLT functions in a node or cabinet, this was referred to as remote OLT or OLT in the node. At the core of the next generation DAA DPoE systems there are three different distributed access architecture types that will be defined and evaluated in this paper. These define the functions that will be placed in the node or cabinet locations as well as those that may be placed at the facility; the facility may be a hub site or the cloud like a regional data center (RDC).*

## OVERVIEW OF CAA AND DAA FOR PON

This paper defines the centralized and distributed access architectures for PON. We have compiled an evaluation criterion for a side-by-side comparison of these different types of PON access architectures, so that a multiple system operator (MSO) can be aware of the next generation OLT or DPoE System possibilities.

The terms centralized access architecture (CAA) and distributed access architecture (DAA) are being used in the cable networking space. The term CAA means that the network media access control (MAC) and physical (PHY) layers are placed into systems in the service provider's facility, shown in Figure 1. The distributed access architecture places MAC and PHY layers or just the PHY layer in the outside plant node, cabinet or MDU location. If we consider cable deployments for DOCSIS, these utilize the centralized access architecture, which keeps the access MAC and PHY layers for DOCSIS in the service provider facility, while maintaining a transparent outside plant network. This is also the case with many PON deployments in the cable and telco space: the PON MAC and PHY are located in the facility enabling the outside plant (OSP) or optical distribution network (ODN) to remain passive and transparent.

The development of remote OLTs, since as early as 2002, placed the OLT MAC and PHY in a node or cabinet enclosure, but this did not garner significant market share. Most service providers preferred a centralized OLT that used a passive optical distribution network (ODN). However, placing the OLTs in the Headend/Central Office (HE/CO) facility may restrict the reach between the HE/CO and end users and/or reduce the split ratio and the number of subscribers served per OLT port. In recent years, there have been innovations to extend the reach or amount of subscribers per port of the centralized OLT architecture by

placing an active networking device in the node or cabinet, called a PON Extender, while keeping the PON MAC and PHY in the facility.

The PON Extender is a powered device that could be placed in a carrier facility, cabinet, strand mounted node enclosure, or MDU building. The PON extender does not contain the OLT MAC and PHY, making this a centralized access architecture. The PON extender architecture may allow the OLT at the facility to use Coarse Wavelength Division Multiplexing (CWDM) or Dense Wavelength Division Multiplexing (DWDM) optics to the PON Extender. Then the PON extender may perform an optical-to-electrical-to-optical (O-E-O) conversion and then standard PON wavelengths are used at the customer facing side of the PON Extender, as shown in Figure 2.

Some of the drivers and benefits found in deploying the remote OLT architecture can be achieved with the PON extender architecture, but without placing the OLT PON MAC and PHY and even higher layers in the outside plant. There are architecture and performance differences between PON extender and remote PON MAC and PHY architectures. A paper examined some of these differences between PON extender and remote OLT architectures titled "*Remote PON Network Performance*", by Edward Boyd, et.al., published at the 2015 NCTA / INTX conference. Our paper also includes some analysis work of the PON extender architecture and more work is currently underway to improve the capabilities.

There are two types of centralized access architectures for PON. The first is the traditional approach of placing the PON OLTs in the service provider's facility and having a completely passive OSP / ODN, as seen in Figure 1. In Figure 2, the PON MAC remains in the facility, like the headend, and a PON extender is used in the optical distribution

network (ODN). The PON extender may be used to increase the subscribers per PON OLT port while also saving space in the facility, increase the serving area distance between OLT and customers, and also to increase the number of PON links per fiber, from 1 to perhaps 16 or more.

Centralized Access Architecture (CAA) – PON attributes are listed below:

- OLT MAC and PHY are located at the Facility
- Complex Systems are not in the ODN / OSP

- ODN may be completely passive (no actives)
- ODN may have an active for a transparent O-E-O conversion of WDM optics to PON optics called a PON Extender
  - PON Extender creates an Active Optical Network (AON) not a Passive Optical Network

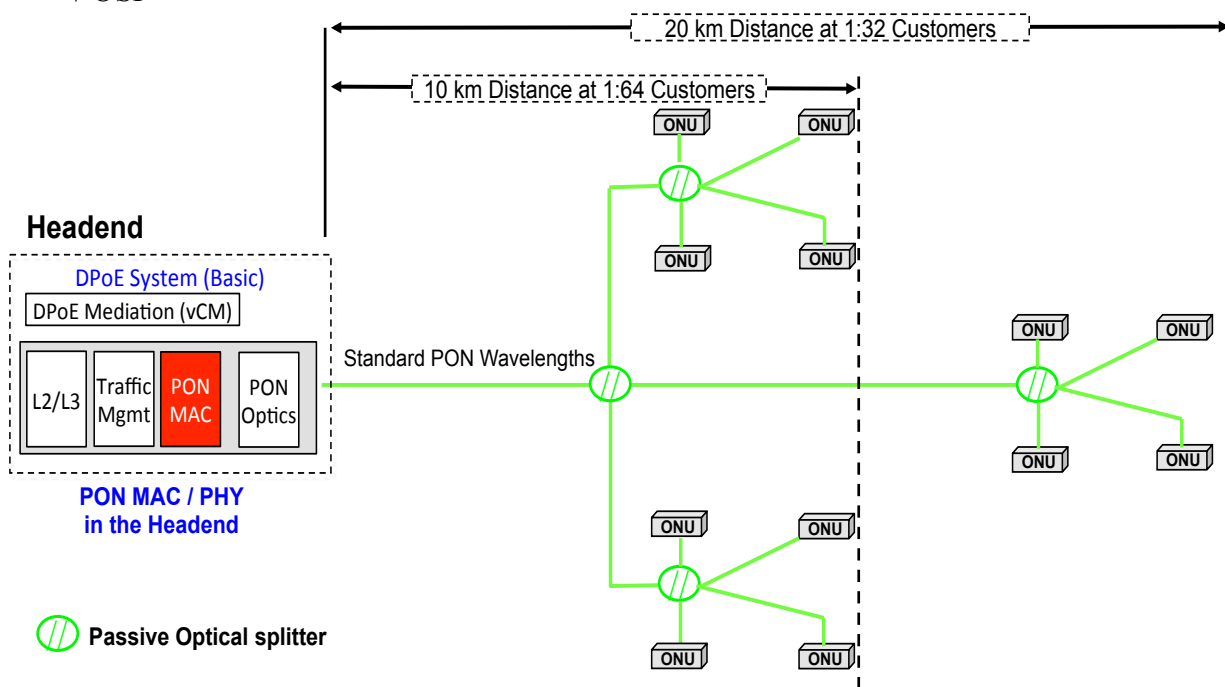

Figure 1 – High-Level – CAA DPoE System

The second CAA for PON keeps the PON OLT (MAC and PHY) in the service provider facility, but uses a PON extender device in the OSP / ODN, as seen in Figure 2. The PON extender architecture estimates a 128 way split at 2 km, however 5 km has also been tested. This illustrates support for multiple 10G EPON service groups or 10G EPON links served from a PON extender. The PON extender uses CDWM or DWDM to carry the equivalent of multiple 10G EPON links to the serving area. The PON extender then

connects to different fibers serving different groups of homes or neighborhoods using standard PON optics, this allows all Optical Network Units (ONUs) to use standards 10G EPON optics.

In many ways, the PON extender solves the stacking of multiple 10G PON links using different wavelengths defined in NG-PON2. The NG-PON2 standard currently defines 10G (9.95G) as the maximum upstream and downstream PHY rate between an ONU and

OLT. NG-PON2 requires tunable optics in the ONU to select one of the 4 to 8 wavelengths across the PON.

Currently, a PON extender may support eight (8) 10G EPON links per node and sixteen (16) 10G EPON links per fiber, this is 80 Gbps and 160 Gbps of PON capacity per serving area. The use of different fiber paths to different neighborhoods allows the same color or standard 10G wavelength to be used, thus not requiring tunable optics on the ONU.

The use of a PON Extender (or any of the DAA architectures described in this paper) supports multiple 10G wavelengths to the serving area and then multiple 10G EPON links from the node to the customers using different fibers to different neighborhoods, as seen in Figure 3. Placing an active in the outside plant and fiber topologies to the neighborhood allows 10G EPON to have even more capacities than NG-PON2 at less costs due to the avoidance of tunable optics on the ONU.

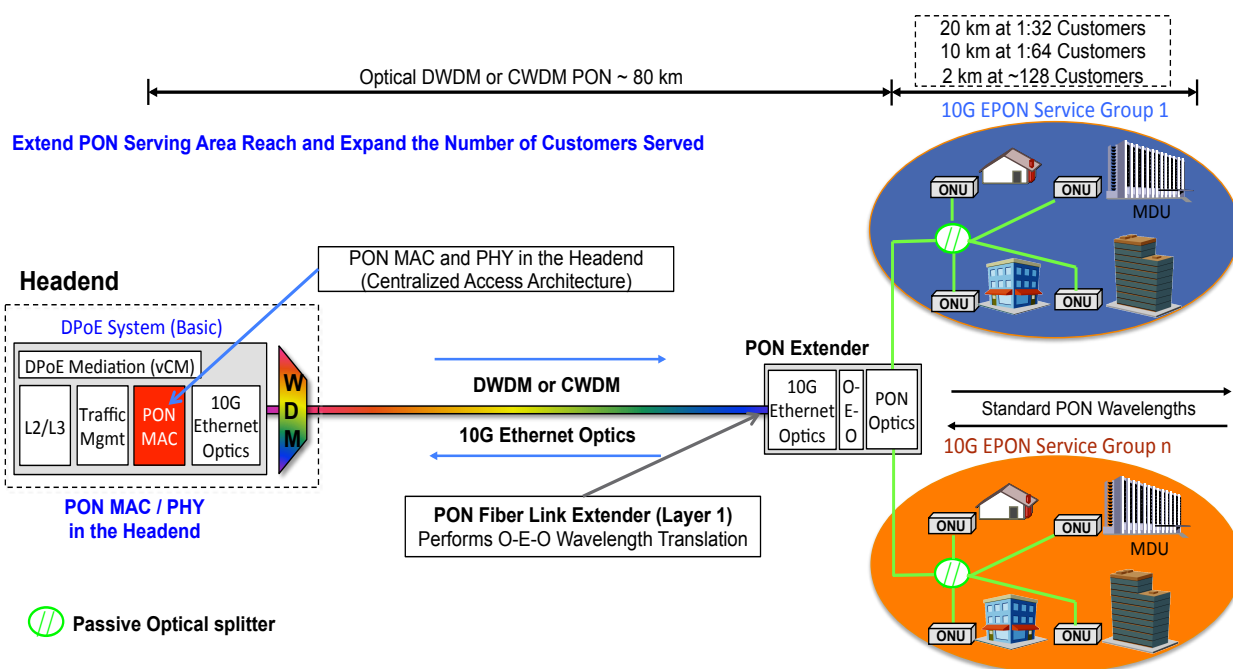

Figure 2 – High-Level – CAA PON Extender Network Architecture

The distributed access architecture for PON places the MAC and PHY of the OLT in the outside plant (OSP) / optical distribution network (ODN) as shown in Figure 3. The attributes of distributed access architecture are listed here.

### Distributed Access Architecture (DAA) – PON

- The OLT MAC and PHY are always distributed and located outside an MSO facility in the ODN (node or cabinet)
- ODN definitely has an active device
  - Active Optical Network (AON) is not a Passive Optical Network
- Layer 2 / 3 architecture

- Requires Two (2) Data Transport Networks:
  - Trunk Link: Data Link Between Facility and Node (likely P2P)
  - Line Network: Node to Subscribers uses the PON MAC & PHY as well as PON optics
- Generally Called a “Remote OLT” (R-OLT)
  - This paper defines several system architectures when placing the PON MAC and PHY in the OSP/ODN
  - There may be several product form factors such as a strand-mounted node, field hardened cabinet device, or OLT for the MDU

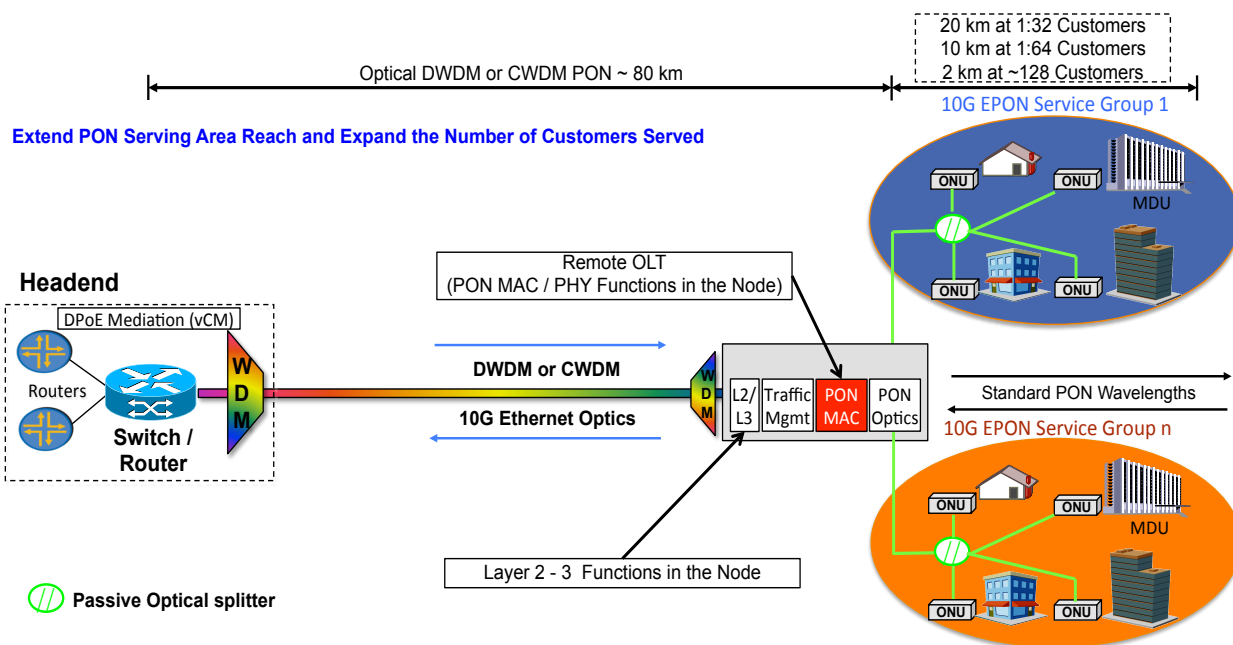

Figure 3 – High-Level – DAA - Remote OLT Network Architecture

The figures above highlight in red the location of the PON MAC and include other system functions in each architecture. In Figure 1, notice that the centralized OLT with a passive optical network, uses an optical wavelength plan defined by the IEEE or the ITU-T. The use of an IEEE defined wavelength plan will allow a fiber to carry a single PON. This means that if a service provider wanted to support more customers than that carried on the single fiber the operator would need another fiber between the facility and serving location. The number of fibers in a given serving area, like a neighborhood, is finite and it is expensive to build additional fibers from the facility to a serving area, thus service providers want to

leverage the fibers they have in place. Some service providers may have enough fibers to support the desired number of customers without building new fiber. Many service providers will require the PON network to carry multiple wavelengths between the facility and the serving area to maximize the fiber utilization. Figures 2 and 3 use CWDM or DWDM enabling the existing fibers in the service area to support the customer needs.

This paper will define another architecture similar to Figure 1 that allows 10G EPON to use different wavelengths without requiring a PON extender in the field. This approach may adopt the NG-PON2 wavelength plan for use in 10G EPON OLTs and ONUs. This

paper will discuss several approaches to enable this function. Additionally, this paper will define new system architectures for what was known as remote OLT, this paper proposes that by placing different types of functions in the node these should be classified as different devices, not simply remote OLT.

## DRIVERS AND ASSESSMENT FOR NEXT GENERATION PON ARCHITECTURES

The service providers are considering placing active, powered devices, in the optical distribution network to solve several challenges. There is also interest in the future evolution of the network to support a migration to a software defined network (SDN) and also network function virtualization (NFV). This paper also proposes several next generation DPoE system approaches that can support the business drivers listed below. This paper examines some methods that could be adopted by 10G EPON to solve some of these challenges and avoid placing actives in the ODN, referred to as multiple wavelength “Multi-wave” 10G EPON. This paper introduces several next generation DPoE system approaches in the distributed access architecture class.

### **Business Drivers for the Next Generation DPoE Systems**

1. Improve Cost end-to-end (E2E) (OPEX and CAPEX)
2. Maximize Fiber Utilization
3. Increase Serving Area Distance
4. Improve Space and Power Utilization
5. Support Software Defined Network
6. Support Network Function Virtualization

In this paper, we have expanded the business drivers to be part of an overall assessment criteria, as seen in the list below.

We have added overall space, power and scaling of the network end-to-end. We have added some performance difference for capacity and latency. The system needs to have support desired availability thresholds, as the system may need to have internal system protection schemes as well as network protection architectures. The complexity tolerance of the system varies in large part by the location of the subsystem functions but also by the number of the devices required to enable complete DPoE system operations. Placing all of the DPoE subsystem functions in the node may reduce the reliability, as there are more hardware components in the node. However, splitting subsystems functions between the facility and node location may increase complexity of the next generation DPoE system. If a network service can be delivered by a completely passive optical network (PON), with no active or powered devices in the ODN or outside plant (OSP), then this is generally preferred by most service providers. If the service provider moves to an active optical network (AON) this is generally done to solve some of the business drivers listed earlier. As with most situations there are tradeoffs as well as other drivers that are considered when selecting a system and network architecture. The assessment criteria define how we approach assessing the current and next generation DPoE system architectures.

### **Assessment Criteria of Access Architecture**

1. Improve Cost end-to-end (E2E) (OPEX and CAPEX)
2. Maximize Fiber Utilization
3. Increase Serving Area Distance
4. Space/Power/Scaling Utilization in HE
5. Space/Power/Scaling Utilization in ODN
6. Support Software Defined Network
7. Support Network Function Virtualization
8. Assess Capacity and Latency Performance Differences
9. Assess High Availability System / Network Differences

## 10. Assess System and Operational Complexity Differences

### DETAILED DPOE SYSTEM FUNCTIONS

The term DPoE system refers to the set of subsystems within the hub site that provides the functions necessary to meet DPoE specification requirements, according to the DPoE-SP-ARCHv2.0-I04-150611 specifications. The DPoE specifications and perhaps others would certainly need to evolve to support some of the proposed solutions found in this paper. Figure 4 illustrates the high-level set of subsystems that comprise the DPoE system within an MSO hub site or facilities. Figure 5 introduces the functions within the OLT subsystem and renames vCM to DPoE Mediation Layer. These subsystem blocks are important in understanding the types of remote PON architectures, because the location of these subsystems in many way define the type of DAA for PON.

The DPoE specification, referenced previously, defines the Virtual Switching Instance (VSI) functional block shown in Figure 4, Figure 5 and Figure 6. The purpose of the VSI is to support bridging, learning, and forwarding within a layer 2 service instance. The VSI would forward the frames based on standard [802.1d] bridging (unqualified learning via [802.1d]; or qualified learning via [802.1d] + [802.1Q]) behavior to the appropriate pseudowire spoke, VPWS, or local attachment circuit

[CableLabs]. The DPoE specification allows the VSI function to be “distributed”, contained within the DPoE system or maybe “centralized” not in the DPoE system where the service interface is provisioned. In the centralized bridging and forwarding model the [802.1] bridging/learning occurs on some remote system (i.e., not on the DPoE System where the service interface is provisioned) [CableLabs]. The VSI block and the supporting encapsulation methods like MPLS, shown as Provider Edge (PE) or VPLS Edge (VE) in Figure 4, 5 and 6 may not be part of the DPoE system if a “centralized” forwarding model is used.

It is important to note that the use of “distributed” or “centralized” for purposes of bridge or Virtual Switching Instance (VSI) for the forwarding models of layer 2 traffic should not be confused with the CAA and DAA for PON described in this paper. In other words, the use of the terms centralized and distributed for the forwarding models of layer 2 bridging and learning for a VSI are to be treated separately. The VSI functional block in a “fully distributed model” may be part of any CAA or DAA for PON class or subclass. Later in this paper, the use of term Remote DPoE System (RDS) will be applied to a device outside the facility, such as node, cabinet, or MDU basement, and this device may use the centralized or distributed VSI forwarding models. The Remote DPoE System (RDS) supports either forwarding model just like the hub based DPoE System architecture.

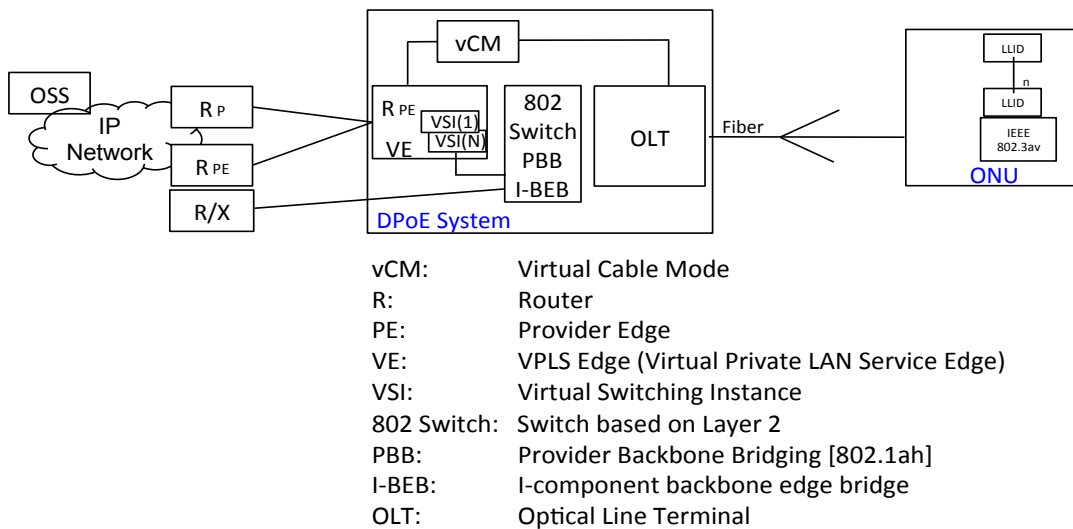

Figure 4 – CableLabs DPoE System Based on DPoE-SP-ARCHv2.0

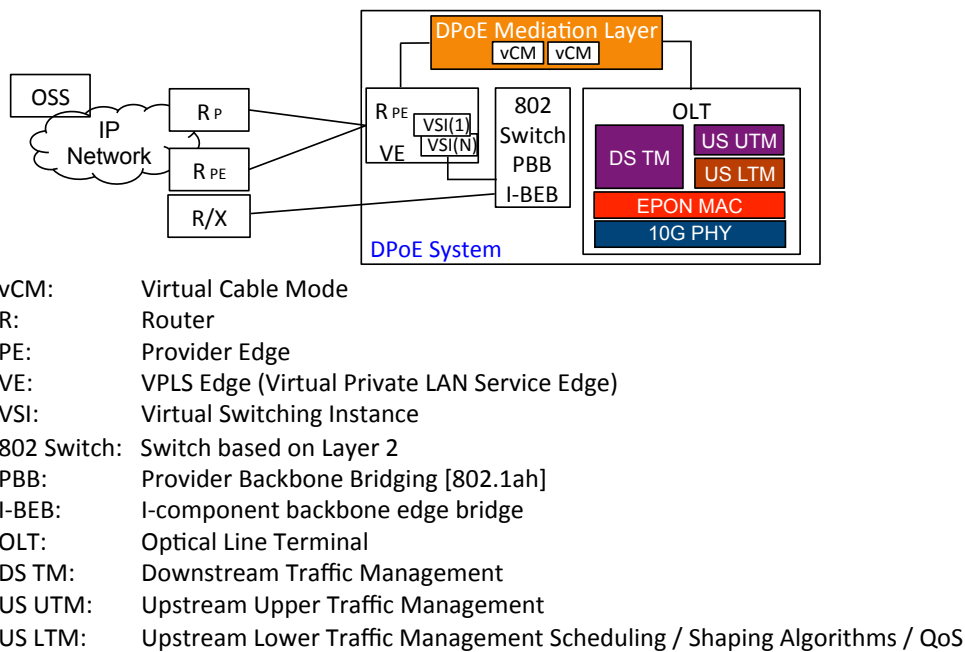

Figure 5 – OLT and DPoE Mediation Layer Subsystems

This paper illustrates and defines the DPoE subsystems in more depth and detail. This may include some functions that could be considered out of scope for DPoE 2.0 and also those that others may consider not to be a part of a DPoE subsystem. This detailed view of the subsystems for DPoE will be critical in understanding the functions that could be placed in the remote node or cabinet location.

Additionally, the DPoE subsystems can become part of the Software Defined Network (SDN) and also Network Function Virtualization (NFV). Figure 6 provides a detailed view of the subsystems that comprise a DPoE System. After the figure roles and functions of the some the subsystem blocks.



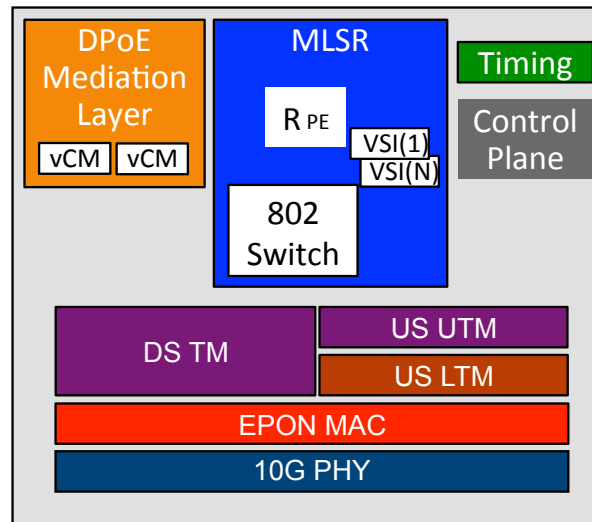

Figure 6 – Detailed Illustration of the DPoE Sub System Functions

### Multilayer Switch Router (Control & Data Plane)

- Router (R)
- Address Resolution Protocol (ARP)
- Neighbor Discovery Protocol (NDP)
- Intermediate System to Intermediate System (IS-IS)
- Open Shortest Path First (OSPF)
- BGP (Border Gateway Protocol) only supported IPv4 unicast prefixes
- MP-BGP (Multiprotocol BGP) supports different addresses: IPv4/IPv6 unicast, IPv4/IPv6 multicast, and MPLS VPN where we use MP-BGP to exchange the VPN labels.
- Multiprotocol Label Switching (MPLS)
- Provider Edge (PE)
- Virtual Private Wire Service (VPWS)
- Virtual Private LAN Service (VPLS)
- Virtual Switching Instance (VSI)
- 802 Switch based on Layer 2
- Provider Bridging [802.1ad]
- Provider Backbone Bridging [802.1ah]
- I-component backbone edge bridge
- DHCP Relay
- Interface Access Control Lists

### Control Plane Functions

- Centralized Control for all required configurations (e.g. port, channel and MC domain etc.)
- Centralized Control for sending all the collected stats (e.g. port, channel and mac domain etc.).
- EPON MAC for programming all required functionality (e.g. port, channel, LLID and upstream QoS etc.).
- DS TM for programming all required functionality (e.g. service flow, classifier, and downstream QoS etc.).
- Implement the control plane for multicast forwarding

### DPoE Mediation Layer Functions

- Mediation between OSS, NMS, and EPON Layers
- Virtual Cable Modem (vCM) for registered D-ONU
- vCM handles all the OAMP functions for DOCSIS
- vCM can proxy requests, signaling, and messages to the D-ONU using EPON OAM messages
- Communicate with D-ONU for provisioning all required services (e.g. IP HSD, MEF etc.)

- vCM Interfaces with System Control Plane for configuration (e.g. service flow, classifier, and downstream QoS etc.)
- Platform Management Interfaces (CLI, SNMP, etc.)

### **Downstream Traffic Management (DS TM):**

- Subscriber Management Filtering (drop)
- Classification & Policing to traffic toward a service flow
- Multicast / Packet Replication
- Scheduling / Shaping Algorithms / QoS Priority of Service Flows (LLIDs)
  - DOCSIS QoS
  - MESP Bandwidth Profile (MEF Metering / Color Marking)
- Packet Counters and Statics (IPDR Raw Data)
- DSCP / ToS / TPID (MEF) Overwrite and Translation
- CoS Mapping
- CALEA / Lawful Intercept
- SF / ASF Encapsulation to VLAN (tunnel ID)

### **Upstream Upper Traffic Management (US UTM)**

- CALEA / LI
- DSCP / ToS / TPID (MEF) Overwrite
- CoS Mapping
- Packet Counters and Statics (IPDR Raw Data)
- Subscriber Management Filtering (drop)
- Cable Source Verify / MAC Learning / Protocol Throttling
- Classification & Policing for forwarding toward the NNI or backplane (aggregate rate limiting)

### **Upstream Lower Traffic Management (US LTM)**

- Scheduling / Shaping Algorithms / QoS Priority of LLIDs (Service Flows)
  - Dynamic Bandwidth Allocation (DBA) – solicited scheduling
    - Token Size per LLID

- Polling Interval per LLID
- Scheduling / Queuing Algorithm
  - Unsolicited Scheduling
  - MPCP Processing
  - The figure shows two blocks called US TM, because it is common that this lowest layer function is found with the EPON MAC subsystems but this is an upstream TM function)

### **EPON MAC Layer**

- LLID to VLAN (tunnel ID)
- Operation, Administration, and Management (OAM)
- Multipoint Control Protocol (MPCP)
  - Discovery & Registration
  - GATE Generation
  - REPORT Processing
  - Round Trip Time
  - LLID / Preamble (Frame Formation)
- Encryption DPoE 10G - AES 128 Counter Mode (CTR) is bidirectional
- Encryption SIEPON - GCM-AES 128 is bidirectional

### **EPON PHY Layer**

- FEC
- PR-type PMD (PON Optics)

This is an illustration of the subsystems and possible subsystems that comprise a modern 10G EPON DPoE System. These functions are important to understand as this paper examines future system architectures that may change or split the subsystem functions between the hub site and the node location as well as to the cloud, hub site, and node location. Figure 6 is used to illustrate the subsystem block location of the next generation DPoE system architecture. This paper also illustrates and defines new subsystem functionality blocks needed to support the next generation DPoE systems.

These may include wavelength management for the Multi-wave DPoE 10G System, MACsec for encrypted communications with remote PON nodes and cabinets, new communication methods for provisioning and managing remote subsystems, timing, and more. In this paper, we assume extended DPoE System includes functionalities for DAA architectures such as discovering, authenticating and secure provisioning, maintaining and managing Remote Devices, vCM creation and management, OSS/BSS interfacing. Some of these functionalities may also reside in a separate controller.

DOCSIS may have the MAC and PHY layers in same facility or the MAC and PHY layers could be in separate MSO facilities, for example the MAC core could be in the headend and a PHY shelf in the hub location. The CAA for PON may have all of the DPoE system functions in one facility or may be separated in between headend and hub site as well. The CAA for PON architecture has the OLT subsystem that contains the PON MAC and PHY in the service provider’s facility and when the OLT subsystem is placed in the outside plant or non-carrier facility like an MDU this is referred to as distributed access architecture (DAA).

### OVERVIEW OF THE NEXT GENERATION CAA AND DAA FOR PON OPTIONS

#### CAA for PON Overview

The centralized access architecture (CAA) is an architecture where the MAC and PHY functions for the access layer are located within a carrier facility. The CAA for

#### Integrated DPoE System (IDS)

The DPoE specifications did not define the name of the device that includes all of the subsystems in a single platform. In this paper, this is referred to as an Integrated DPoE System (IDS), as shown on the top of Figure 7.

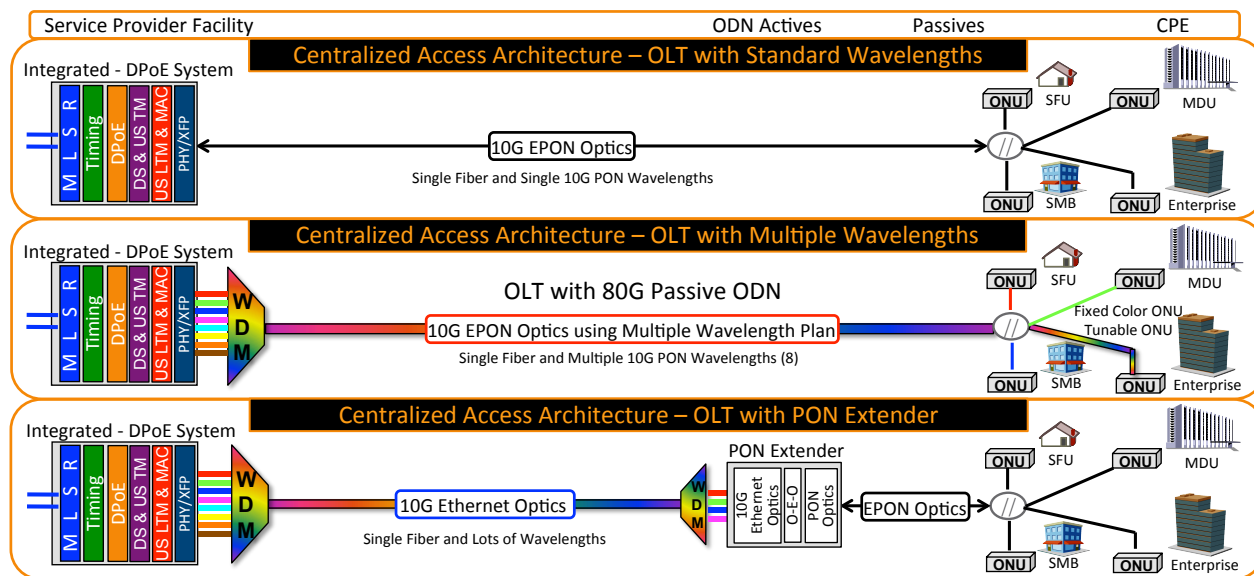

Figure 7 – Centralized Access Architecture (CAA) for PON Options

If the subsystems remained separate the existing platform names would be used, such as OLT, switch, multilayer switch (MLS), router, P-router, PE router, and more. The DPoE mediation layer, that contained the virtual cable modem (vCM) functions, was either integrated into one of the subsystems or a standalone server model. The earliest deployments of DPoE subsystems used the standalone server model. A modern DPoE subsystem architecture has integrated the DPoE mediation layer functions into one or more of the subsystems. As this paper is being published, there is interest in the industry to adopt the server model approach again, this time called, DPoE Mediation in the cloud as part of a SDN architecture.

A 10G DPoE system with MAC and PHY functions using IEEE standard PON wavelength is shown on the top of Figure 7 and implemented as an Integrated DPoE System (IDS), whereby all of the DPoE subsystems are placed in a single platform. This deployment architecture and use of standard 10G EPON wavelengths allow a single 10G PON per fiber, the service provider must have additional fibers to a serving area to provide additional 10G capacity.

#### Multi-wave Integrated DPoE System (MIDS)

This paper also proposes a Multi-wave Integrated DPoE System (MIDS) as part of the CAA architecture, as shown in the middle of Figure 7. The Multi-wave Integrated DPoE System does not use the standard IEEE 10G wavelengths, but rather suggests the adoption of the NG-PON2 wavelength plan to be use in the 10G EPON OLTs or DPoE Systems. The adoption of the NG-PON2 wavelength plan does not require the use of tunable optics at the ONU, but this is optional in this proposal. This proposal would adopt the NG-PON2 wavelength plan, but not all of the optical requirements for use in the 10G EPON system.

The 10G DPoE system may use a single wave or fixed wavelength solution to the ONUs. There are operational challenges with fixed optics solutions and there are cost improvements under development for tunable optics. There are also operational benefits in having an all passive network, this avoids actives in the outside plant and associated equipment like battery supplies and ongoing plant power and maintenance. The pros and cons of this proposal as well as others are examined later in this paper. The 10G DPoE System that supports multiple wavelengths is called Multi-wave DPoE System. In this paper, because we illustrate all of the DPoE subsystems in a single system, the multiple wavelengths are called the Multi-wave Integrated DPoE System or MIDS.

#### PON Extender

The PON extender has been used for 1G EPON and GPON systems for many years, and most recently 10G EPON systems, as shown on the bottom of Figure 7. The PON extender increases the serving area distance from the service provider's facility to the customers. The PON extender likely increases the number of customers served per PON port at the facility. The use of the PON extender allows for multiple CWDM or DWDM wavelengths between the OLT in the facility and the PON extender node link and then uses standard PON optics from the PON extender to the ONUs. The PON extender introduces an active component in the ODN, but this is not considered a distributed access architecture, because all of the DPoE subsystems remain in the facility.

The PON extender's use of an optical-to-electrical-to-optical (O-E-O) conversion process places the lowest layer of the PHY in the remote the device, called the Physical Medium Dependent (PMD) sublayer PRX-type PMD (clause 75) [IEEE]. This is the PON optics transmitting at 10.3125 GBd

continuous mode and receiving at 1.25 GBd burst mode, for asymmetric-rate operations (referred to as 10/1GBASE-PRX-D) [IEEE]. A symmetric-rate PMDs (referred to as 10GBASE-PR-D) is possible transmitting at 10.3125 GBd continuous mode and receiving at 10.3125 GBd burst mode [IEEE]. The authors considered referring to the PON extender using O-E-O as a remote PHY option for PON, but since all other PHY functions like the FEC remains in the OLT at the facility we decided to place PON extender in the CAA class.

The PON extender is active component requiring minimal power and no intelligence compared to distributed DPoE subsystem architectures as shown in Figure 7 and described later in this paper. The PON extender is most analogous to the HFC node in the cable world; performing media conversion and minimal processing with no software.

#### CAA for PON using SDN or NFV

In this architecture higher layer DPoE system functionality may be integrated in the same physical headend shelf or some functionality may be moved to the MSO cloud.

Though in Figure 7, the DPoE subsystems are shown in a single system, we term as an Integrated DPoE System. In the future the DPoE subsystems may use a software defined network (SDN) architecture design and the control and data plane processes may then be separated. The control plane processes may be placed on servers and the control traffic through spine switches. As a next step to evolve to a programmable network and service architecture, the management and configuration functionality may be abstracted and implemented in the SDN controller.

Additionally, using a Network Function Virtualization (NFV) architecture design, both

control and data plane processes may be placed on servers and traffic through spine switches. Furthermore, functionalities such as routing/switching, traffic management, and DOCSIS mediation may be virtualized and implemented on the commercial off-the shelf (COTS) hardware and eventually moved to the MSO cloud. An orchestrator is then implemented to manage transactions between these functions and controller. The goal of the SDN and NFV architectures is to reduce capital and operational costs. Additionally, there is a belief that faster delivery of new services through SDN and NFV evolution is possible for all these architectures.

#### DAA for PON Overview

This paper defines a new class of OLT or DPoE System architecture called distributed access architecture for PON or DAA for DPoE System. The distributed access architecture has defined three subclasses, the Remote PON MAC (RPM), Remote OLT (R-OLT), and Remote DPoE System (RDS). There may be variants within these subclasses of DAA for PON, but in general these define the key subclasses.

As described above, an architecture that uses SDN and NFV may be applicable to these architectures as well, and this is described further in this section. The section above called Detailed DPoE System Functions may be helpful in understanding the location of the subsystem functions as the DAA for PON places some or all of the DPoE subsystems outside the hub and into the ODN. The following describes the three subclasses for the distributed access architecture for PON, shown in Figure 8. As stated above there can be variants within these three classes.

Additionally, the SDN architecture for control plane and NFV for control and data plane can place these functions in the cloud on COTS hardware and software. We have chosen not to show the control plane on

external devices and we have also not shown the systems in the facility that could be part of a cloud based NFV architecture as well. We

have separated the functions and these functions may be placed in an SDN or NFV architecture as desired.

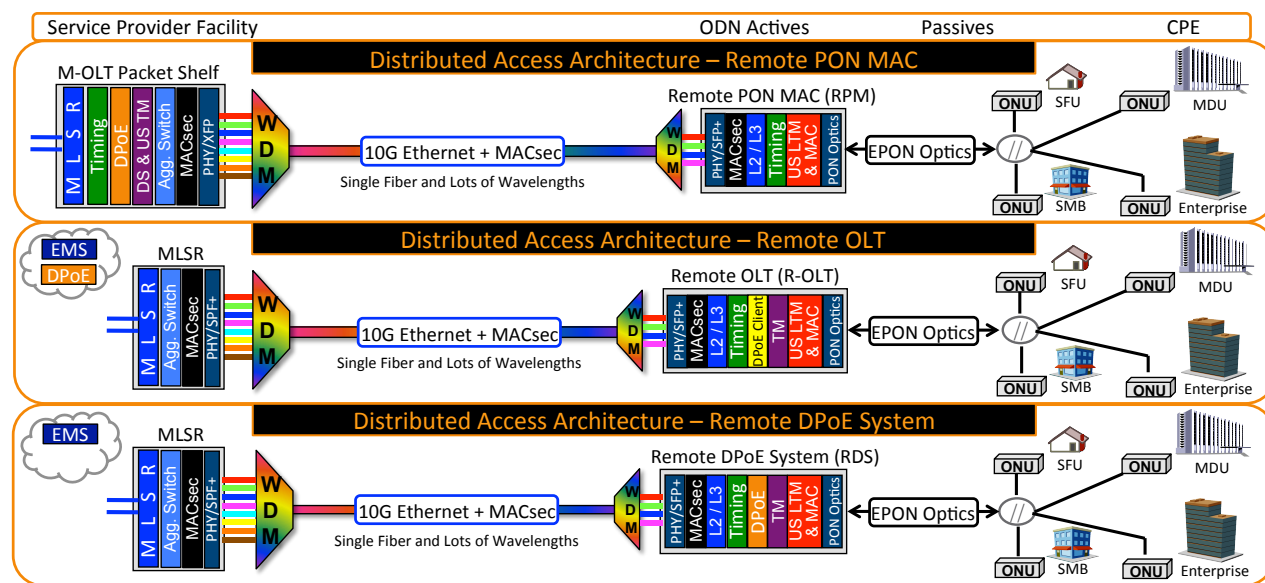

Figure 8 – Distributed Access Architecture (DAA) for PON Options

This paper defines the location of each subsystem functional block from a data plane perspective at minimum. Placing more subsystem functions in the node assumes the carrier is not likely planning to place those functions as part of their NFV architecture today, yet they could be part of a SDN, control plane architecture in the future. This assumes that a service provider would not desire to pay for the hardware, space, and power in the outside plant equipment, node or cabinet, if some functional blocks would later be removed and placed in the NFV cloud. In other words, the carrier would likely use remote subsystem functions that it believes would not be part of NFV architecture.

#### Remote PON MAC (RPM) and Modular OLT

The Remote PON MAC (RPM) access architecture splits the OLT functions in two parts, with one part in the facility containing the downstream and upstream upper traffic

management subsystem and the part in the remote device containing the upstream lower traffic management, PON MAC, and PON PHY subsystem functions. A key concept is that the OLT block, shown in Figure 5, assumes that the PON MAC and PHY as well as the traffic management functions were combined to form the OLT subsystem block as part of the DPoE system. The top of Figure 8 illustrates a device called a Modular Optical Line Terminal (M-OLT) containing all of the downstream traffic management functions and upstream upper traffic management functions in the facility, while the Remote PON MAC (RPM) device contains the upstream lower traffic management, PON MAC, and PON PHY subsystem functions. The Remote PON MAC will also include functions found in the routing and switching block dependent on service provider requirements, but most likely will be configured with a basic IEEE 802 switch.

A remote device defined using the Remote PON MAC (RPM) architecture MUST contain the upstream lower traffic management, PON MAC, and PON PHY subsystem functions. The RPM devices MUST NOT place the downstream traffic management, upstream upper traffic management, and DPoE mediation layer functions in the remote device; these functions are placed in the facility.

The upstream traffic management (US TM) function in the RPM is responsible for upstream scheduling, QoS, shaping, REPORT, GATE, and LLID generation. This small portion of the upstream traffic management is typically part of the system on a chip (SoC), which includes the PON MAC and PHY. The remaining upstream upper traffic management functions as well as all of the downstream traffic management functions that comprise the Modular OLT (M-OLT) subsystem were covered in the sections titled, detailed DPoE system functions.

If we consider that the DPoE subsystem, shown in Figure 5 contained a box called OLT, then the M-OLT and RPM architecture splits the OLT function in two pieces. The Remote PON MAC system architecture, shown in Figure 8, combines the Modular Optical Line Terminal (M-OLT), which has the downstream, and upstream traffic management subsystem with all of the other subsystem blocks to be called a Modular Optical Line Terminal (M-OLT) Packet Shelf.

The EPON MAC functions for the downstream and upstream as well as a portion of the upstream traffic management functions are placed in the remote PON MAC (RPM), this could be a node or cabinet form factor. In this architecture the majority of the software and packet processing are handled at the facility and in this case the M-OLT Packet Shelf, but this could be cloud-based system in part or in whole. The M-OLT packet shelf in this system architecture contains the DPoE

mediation subsystem as well as element management of perhaps hundreds of RPMs that may be served in the field. In many ways the RPM is an extension of the I-DPoE System (IDS) in that it is extending the PON MAC and PON port from the line card to the node location.

The concept of a modular OLT (M-OLT) subsystem and a Remote PON MAC (RPM) device subsystem, or RPMD is an illustration of a next generation DPoE System. In this case the traffic management functions of the OLT are retained in the service provider's facility (hub, headend, central office, data center, or cloud) and the PON MAC and PHY are placed in the field (node or cabinet) or MDU location. Additionally, new blocks for link encryption are added in the NG DPoE system architecture as well as other functions described later in this paper that are shown at the top of Figure 8.

#### Remote OLT

The remote OLT access architecture places the entire OLT functions in the remote device, including the PON MAC as well as all of the PON upstream and downstream traffic management functions. The R-OLT architecture does not place the DPoE Mediation Layer subsystem functions in the remote device. The Remote OLT architecture places the DPoE mediation layer functions handling the northbound provisioning system interfaces and vCM in the facility, on a standalone server model or integrated into a network element. The DPoE mediation layer sends control plane communication messages southbound to the R-OLT subsystems. This may require a thin client for processing and parsing of these control messages in the R-OLT as seen in the middle of Figure 8. The Remote OLT will also include functions found in the routing and switching block dependent on service provider requirements, but most likely will be configured with a basic 802 switch.

The Remote OLT (R-OLT) MUST place downstream and upstream traffic management functions, PON MAC, and PON PHY in the remote device. The R-OLT MUST NOT place the DPoE mediation layer functions, such as Virtual Cable Modem in the remote device; this function is placed in the facility.

This architecture also introduces an element management system (EMS) to manage the five core areas of the Telecommunications Management Network (TMN) model key functions of fault, configuration, accounting, performance and security (FCAPS). The northbound EMS interfaces to network management systems SNMP, CLI, IPDR, authentication and access, and inventory systems. There is ongoing work to define YANG models with NETCONF protocols to configure/manage remote devices. Although the parts that are configured change for the three DAA architectures, YANG models may be applied for different options. The southbound interfaces communicate with remote OLT network elements.

#### Remote DPoE System (RDS)

The Remote DPoE System (RDS) access architecture MUST place the entire OLT subsystem as well as DPoE Mediation layer subsystem in the remote device. These are the two key building block that separate Remote OLT and Remote DPoE System. The Remote DPoE System will also include functions found in the routing and switching block dependent on service provider requirements. This architecture suggests an element management system (EMS) to manage the RDS devices in the same manner as described in the R-OLT description immediately proceeding.

#### DAA for PON using SDN or NFV

The Modular Optical Line Terminal (M-OLT) Packet Shelf is shown as a single shelf. However, using a SDN architecture design the control plane processes may be separated. The control plane processes placed on servers and the control traffic through spine switches. The data plane may be on purpose built systems. Additionally, using a Network Function Virtualization (NFV) architecture design, both control and data plane processes may be placed on servers and traffic through spine switches. In regards to R-OLT is shown using NFV for the DML only and SDN may be used as well. The PON MAC and a portion of the upstream traffic management functions of the data plane are placed in the RPM node and these cannot be moved to the cloud in this configuration. The entire PON MAC and traffic management functions of the data plane are placed in the R-OLT node and these cannot be moved to the cloud in this configuration.

Finally, the Remote DPoE system (RDS) places all of the data plane functions in the node and may use SDN for control plane functions for routing, switch, and other functions. In the R-OLT and RDS architecture Network Function Virtualization to the cloud are simply very limited or not at all because the service providers decided to place the data plane functions in the node and may only implement SDN for the control plan functions to the data center.

In examining the DAA options for PON if NFV is planned in a significant way, then the top approach in Figure 8, the RPM access architecture would be desirable. If there is limited NFV planned, then investment in R-OLT and RDS would be reasonable. If the lowest amount of software and configuration is desirable for the remote PON device, while staying in the DAA class, then the Remote PON MAC (RPM) would be choice.



EVALUATION OF THE NEXT  
GENERATION CAA AND DAA FOR PON  
OPTIONS

CAA – OLT with Standard Wavelengths

In this CAA for PON, standard 10G EPON wavelengths are used per IEEE 802.3bk specifications as shown in Figure 9. Table 1 summarizes supported splitting ratio and reach lengths for different power budget classes that meet channel insertion loss and dispersion requirements. The maximum nominal distance is 20 km with maximum split ratio 1:64. Depending on the ODN implementation, for a given split ratio, longer

or shorter distances may be achieved. Typical deployments are based on PR30 class while PR40 requires new development for the optics.

The OLT PHY and MAC functionality is implemented in special purpose hardware in the headend or hub. This architecture is an extension of first generation 1G EPON technology with proven deployment. Incrementally SDN and NFV may be adopted to dynamically program network devices and services, deploy COTS hardware and move network function workloads between hardware platforms.

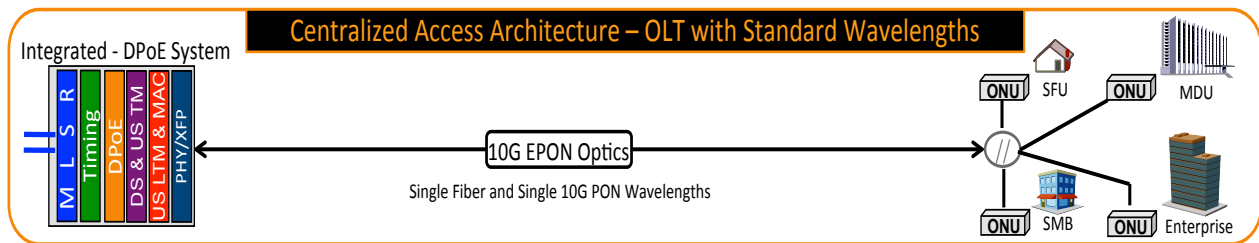

Figure 9 – CAA – OLT with Standard Wavelengths

	<b>10G/1G-EPON</b>	<b>10G/10G-EPON</b>
<b>PON Rate (Gbps)</b>	10.3125G/ 1.25G	10.3125G/ 10.3125G
<b>DS λ (nm)</b>	1575-1580	1575-1580
<b>US λ (nm)</b>	1310 ± 50 Or 1310 ± 20	1270 ± 10
<b>Split Ratio</b>	1:64	1:64
<b>Max Reach (km)</b>	PRX10: ≥10 (1:16) PRX20: ≥10 (1:32), ≥20 (1:16) PRX30: 20 (1:32) PRX40: 20 (1:64)	PR10: ≥10 (1:16) PR20: ≥10 (1:32), ≥20 (1:16) PR30: 20 (1:32) PR40: 20 (1:64)

Table 1 – System Parameters for CAA – OLT with Standard Wavelengths

The major benefits with CAA – OLT with Standard Wavelengths are its technology maturity, lower MTTD/MTTR and operational simplicity thanks to the passive ODN with no space/power requirement in the OSP. Integrated DPoE System functionality can be implemented and operated with current standards and operations practice without requiring an extension to manage distributed architecture devices. However, this architecture has market limitation due to its shorter serving area distance (20 km) and has a higher cost per customer due to its smaller serving group size (1:32/64). Single EPON wavelength per fiber requires additional fiber installation in the ODN to each serving area.

For example, if an MSO built a 500 HHP node architecture during a rebuild, this may have been built with a 2 fiber or 6 fiber node architecture. This meant that the number of fibers allocated to that serving group between the headend and node were designed for between 2 and 6, some MSOs may have more. If the MSO would like to use a CAA with standard 10G EPON optics the fiber constraint and currently occupied wavelength can limit the number of PON subscribers served with exiting fiber. Limited facility consolidation and higher space/power requirements of an integrated headend system are other disadvantages as listed below.

**Pros:**

- **Location of DPoE subsystem hardware:** 100% in the conditioned facility
- **Location of DPoE subsystem software:** 100% in the conditioned facility
- **SDN Architecture Support:** Yes Completely
- **NFV Architecture Support:** Yes Completely
- **Operations MTTD/MTTR:** Lowest
- **Plant Actives:** None

- **Plant Space/Power:** None (no actives, no batteries, no electricity, no maintenance ever)
- **Optical Impact:** All CPE use same optics
- **Number of Optical Ports in the Access Layer:** 1

**Cons:**

- **Fiber Utilization:** single wavelength per fiber may have no impact when service take rates are low. Some MSOs may not have enough fiber strands between headend and node serving areas for full scale PON deployment.
- **Serving Area Distance:** up to 20 km and will not cover entire MSO market and will rely on PON Extender for full coverage
- **Facility Consolidation:** precludes massive headend consolidation (20 km limit)
- **Facility Space/Power:**
  - 2 or 4 times more ports (assuming 64 or 32 subs per port) than PON Extender or Non-blocking RPM assuming 128 subs per port.
  - 4, 8 or 16 times more ports than RPM, R-OLT, and RDS if blocking / oversubscription of the node uplink is allowed
- **Cost Per Customer:** CAA PON reduces PON subs to 32-64 per port increasing costs per sub

**Assessment**

MSOs can deploy and operate CAA - OLT with Standard Wavelengths effectively as both the ODN optics and headend OLT with DPoE functionality are well-established and mature technologies. All passive OSP with high reliability, easy troubleshooting, and minimal technician training makes this architecture attractive to MSOs. However limited fiber utilization, shorter serving area distance, smaller serving groups, high space, and power requirements in the facility all limit

the market deployment cases severely for this architecture. Fiber utilization, reach, and split levels may be extended by using NG-PON2 wavelengths and/or a PON extender as described in the next sections.

### CAA – OLT with Multiple Wavelengths

In the CAA – OLT with Multiple Wavelengths, we are proposing that 10G EPON system could use the NG-PON2 wavelength plan, as shown in Figure 7. Similar to CAA – OLT with Standard Wavelengths, OLT PHY and MAC functionality is implemented in the facility and there is no active component in the OSP.

Table 2 summarizes supported splitting ratio and reach lengths for different power budget classes that meet channel insertion loss and dispersion requirements. The maximum nominal distance is 20 km with maximum split ratio 1:64 for 40 Gbps DS and 10 Gbps US and may support 40 km with maximum split ratio 1:32 for 10 Gbps per DS and 10 Gbps per US channel. The standards requirements include up to 1:256 split ratio. Depending on the ODN implementation, for a given split ratio, longer or shorter distances may be achieved. Similar to other PON technologies, NG-PON2 standards include higher reach lengths (i.e. reaching 60 km) with reach extenders if needed. The standards

suggest that longer reach (e.g., 60-100 km) NG-PON2 systems could facilitate CO consolidation and other network architectures and capabilities.

NG-PON2 (ITU G.989) is based on multiple wavelength channel TWDM architecture over a single fiber. 4-8 TWDM channel pairs may be deployed with each channel pair comprising one DS and one US wavelength. In this section, we consider only 10 Gbps per channel option. The ONU lasers and receivers are tunable and assigned a wavelength based on a dynamic wavelength assignment and management functionality. Although static assignment with cheaper non-tunable ONU optics (i.e. fixed color) is possible, large number of ONUs may be impractical to manage. The likely solution for fixed optics to work is to define the area with specific wavelength upfront and use the BSS or OSS to inventory service ability and the wavelength assignment. The next solution would likely scale best with pluggable so that a standard ONU CPE device could be used and the pluggable with the fixed wavelength is selected for the inventory of parts on the truck.

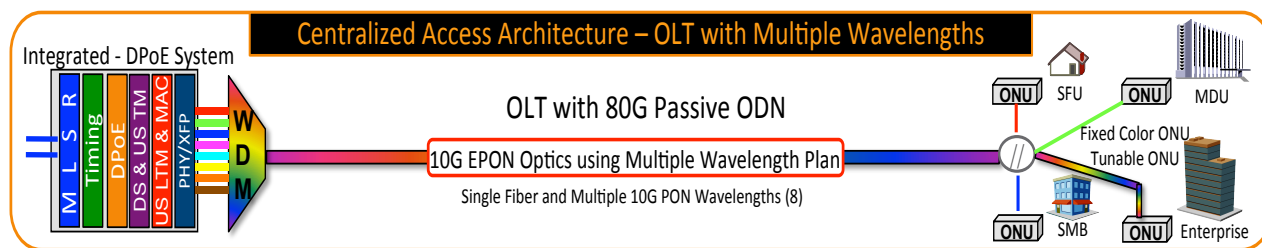

Figure 10 – CAA – OLT with Multiple Wavelengths

	<b>NG-PON2</b>
<b>PON Rate (Gbps)</b>	10.3125G/ 10.3125G
<b>DS λ (nm)</b>	1596 - 1603
<b>US λ (nm)</b>	wide: 1524-1544 reduced: 1528-1540 narrow: 1532-1540
<b>Split Ratio</b>	1:256
<b>Max Reach (km)</b>	20km (1:64 and 40G DS/10G US) 40km (1:32 and 10G DS/10G US) Up to 1:256  N1:PR30; N2; E1=PR40; E2

*Table 2 – System Parameters for CAA – OLT with Multiple Wavelengths*

This architecture has similar advantages with CAA – OLT with Standards Wavelengths option. In addition, multiple wavelength options using Time and Wavelength Division Multiplexing (TWDM) architecture over a single fiber improves fiber utilization without the need of a PON extender or remote OLT device. In table 2, the NG-PON2 standards support 9.953G/9.953G, and when NG-PON2 optics are used for 10G EPON networks, the rate is 10.3125G.

NG-PON2 is a new technology and very few optics vendors have products today. The power budget support of all 4 classes (N1, N2, E1, and E2) require high transmit power at the ONU and high receiver sensitivity at the OLT for upstream. The use of a SOA in the ONU and OLT optics increases the cost significantly. To expedite the use of NG-PON2 core technologies for 10G/10G, a new standard, XGS-PON (ITU-T G9807.1) was developed using fixed wavelength defined by the IEEE 10G EPON standard in 2009 (i.e. 1577 nm DS/1270 nm US). In the meantime, optics suppliers are examining cheaper NG-PON2 optics designs.

There are operational challenges with fixed optics solutions because these will have to be deployed so that operations can manage different wavelength or color ONUs. There are also operational benefits in having an all passive network. It avoids actives in the outside plant and associated equipment like battery supplies and ongoing plant power and maintenance. The use of tunable optics shares the benefits of an all passive network and avoids the operational management of tracking and allocating specific colored ONUs. Tunable optics come at a steep cost to support a tunable range of four wavelengths or more. The use of NG-PON2 wavelengths may increase the maximum reach and split support while keeping OSP all passive; this will be examined later in this paper.

Due to current limitation on the optics technology to support higher split ratios and reach lengths, limited serving area distance and facility consolidation remain as disadvantages. Current NG-PON2 optics prices increase the cost per customer at the ONU and OLT. The use of NG-PON2 optics can support greater reach and greater splits, thus increasing the number of subscribers per port when compared with traditional 10G EPON wavelengths. In most cases PON

extender or DAA for PON architectures that place the PON optics in the neighborhoods and close to the customers will enable more customers per port. The Multi-wave DPoE System does not require actives in the outside plant to enable more links of 10G EPON on the fiber, which is an advantage of this architecture. The pros and cons are list below:

**Pros:**

- **Location of DPoE subsystem hardware:** 100% in the conditioned facility
- **Location of DPoE subsystem software:** 100% in the conditioned facility
- **SDN Architecture Support:** Yes Completely
- **NFV Architecture Support:** Yes Completely
- **Operations MTTD/MTTR:** Lowest
- **Plant Actives:** None
- **Plant Space/Power:** None (no actives, no batteries, no electricity, no maintenance ever)
- **Number of Optical Ports in the Access Layer:** 1
- **Solves Fiber Utilization:** using WDM at the OLT solves fiber utilization challenge of traditional PON and the driver to place actives in the OSP/ODN (PON Extender or remote OLT) enabling service providers to leverage the fiber they already have between facility and node serving area.
- **Operational Benefits:** supporting multiple wavelengths per fiber and having an all passive network save operational costs

**Cons:**

- **Serving Area Distance:** up to 20 km and will not cover the entire MSO market and will rely on PON Extender for full coverage; 40 km may be supported but the split ratio is reduced by half to 1:32 and the optics' price increase

- **Facility Consolidation:** precludes massive headend consolidation (20/40 km limit)
- **Facility Space/Power:**
  - 2 or 4 times more ports (assuming 64 or 32 subs per port) than PON Extender or Non-blocking RPM assuming 128 subs per port.
  - 4, 8 or 16 times more ports than RPM, R-OLT, and RDS if blocking / oversubscription of the node uplink is allowed
- **Cost Per Customer:** CAA PON reduces PON subs to 32-64 per port increasing costs per sub. Optimizing fiber utilization and keeping the ODN a "PON" adds costs to optics OLT/ONU.
- **ONU optics:** Will increase ONU (and OLT) optics cost, volumes will reduce cost but not to the 10G EPON level, tunable ONU enable flexibility at high capital cost or fixed color are lower in cost but will impact operations and require management of colored devices
- **Operational Challenges:** management of different wavelength or color ONUs can be costly

**Assessment**

CAA with NG-PON2 wavelengths improves the fiber utilization by using hybrid time and wavelength division multiplexing channels on a single fiber between the Facility and Splitter node. Therefore, this idea may reduce the market size for PON Extender and remote OLT. However, the biggest challenge today is NG-PON2 optics cost at both the ONU and OLT compared to nearly all other solutions. Aligning 10G EPON TWDM and NG-PON2 TWDM will drive volumes and will reduces cost but the current SOA design will likely not reach the 10G EPON single wavelength level.

We are exploring many different CPE optical wavelength plans and non-tunable

solutions to reduce cost. Customer premise equipment with PON tunable optics increases one-time capital cost of the solution, and also yields an all-passive network for operations. The single wave may reduce capital but will impact operations due to management of different colored pluggables or CPE.

Having a single 10G Ethernet up link, while supporting more than one PON link, is not possible.

### CAA – OLT with PON Extender

The PON Extender may be designed with optical-to-electrical-to-optical (O-E-O) conversion and/or Optical Amplification (OA) based wavelength conversion schemes. An example PON extender with transparent O-E-O conversion of WDM optics to PON optics is shown in Figure 11. The CAA-OLT with a PON Extender expands the split ratio, hence serving group area and the reach extends as shown in Table 3. The high optical transport layer reach enables massive facility consolidation. The PON extender has a one-to-one physical interface mapping from the facility DPoE System across the 10G Ethernet optical link to the PON extender 10G Ethernet link to the PON optic port. The customers served on a PON extender PON port are mapped to a specific 10G Ethernet optical up link port and to a port in the DPoE system.

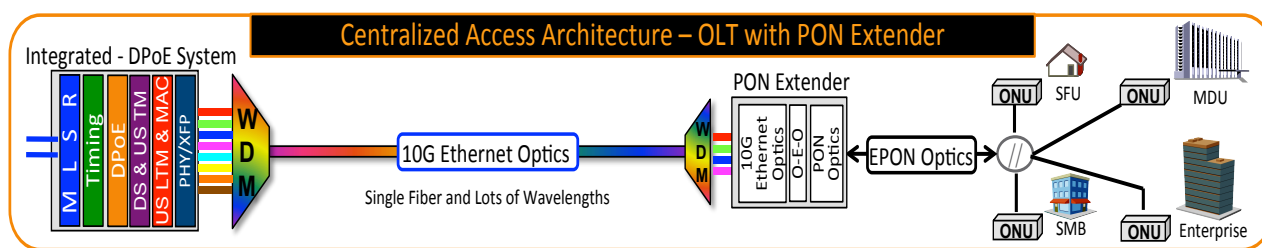

Figure 11 – CAA – OLT with PON Extender

	<b>PON EXTENDER</b>	
	<b>10G/1G-EPON</b>	<b>10G/10G-EPON</b>
<b>PON Rate (Gbps)</b>	10.3125G/ 1.25G	10.3125G/ 10.3125G
<b>DS λ (nm)</b>	1575-1580	1575-1580
<b>US λ (nm)</b>	1310 ± 50 Or 1310 ± 20	1270 ± 10
<b>Split Ratio</b>	1:128	1:128
<b>Max Reach (km)</b>	OTL: 80km <sup>1</sup> ODN: 20km <sup>2</sup>	OTL: 80km <sup>1</sup> ODN: 20km <sup>2</sup>
<small>Note 1: OTL reach depends on the design that affect loss (e.g. MUX/DEMUX) and maximum delay  Note 2: ODN reach depends on the split ratio;</small>		

*Table 3 – System Parameters for CAA – OLT with PON Extender*

The trunk fiber between the OLT in the headend and the PON extender in the node is maximized with the use of a PON extender because each PON port may use a CWDM or DWDM band enabling a single serving area to support multiple 10G PON ports on a single fiber. Due to the PON optical ports proximity to the customers the subscriber count per port is high, this reduces the number of PON port needed and 10G Ethernet wavelengths.

The PON extender may support 10G/10G or 10G/1G EPON. Many MSOs do not prefer co-existence of 1G and 10G on the same PON port due to the throughput degradation and lack of support of 10G and 1G on the same PON extender port is acceptable.

The PON Extender is installed and powered from the plant (e.g. in a cabinet, strand mounted node enclosure, or a facility). Power consumption is small compared to distributed architectures. Although additional optics is introduced, lowest cost Ethernet

optics may be used at the OLT and the PON Extender NNI when no fan out fiber is used. The extender relaxes the transmitter optical power and receiver sensitivity requirements resulting in lower ONU and OLT optics cost.

The extender is interoperable with multi-vendor OLT and ONUs. Although it is an active component in the OSP, increasing operations MTTD/MTTR and requires maintenance, the PON Extender is not as complex as distributed OLT nodes. Minimal technician training and troubleshooting are required compared to remote architectures. The list of pros and cons including facility power/space saving are listed at the conclusion of this section.

#### PON Extender Analysis

The Dynamic Bandwidth Allocation in 10G EPON standards was originally designed and tested for reach length < 20 km. The PON extender trunk distance increases the round

trip time of the link. The extra delay may have a negative impact in the achievable throughput depending on the number of LLIDs and traffic demand and requirements for each LLID. Since ONUs have fixed link queue sizes, if the corresponding LLID has a very high traffic load, the extra delay may cause packet drops.

There are different proposed algorithms to improve the efficiency of long reach PON networks such as multi-thread and real time polling schemes. We are in the process of identifying the delay and jitter issues for different use cases in realistic environments and testing DBA modifications. The key parameters are algorithm efficiency, complexity, reuse of value-added features of widely available chips and support of standard ONUs.

As an example, we performed tests per the setups shown in Figure 12. The maximum achievable US throughput (~8.7 Gbps) depends on total overhead from FEC, burst mode transmission, guard band, idle prefix,

codeword quantization, time quantum rounding, and control messages. First we tested a single LLID case with US and DS traffic for both systems with 0km to show that ~8.7 Gbps (at ODN link level) is achievable in both systems with appropriate SLA parameters, optical overhead, report thresholds and traffic load.

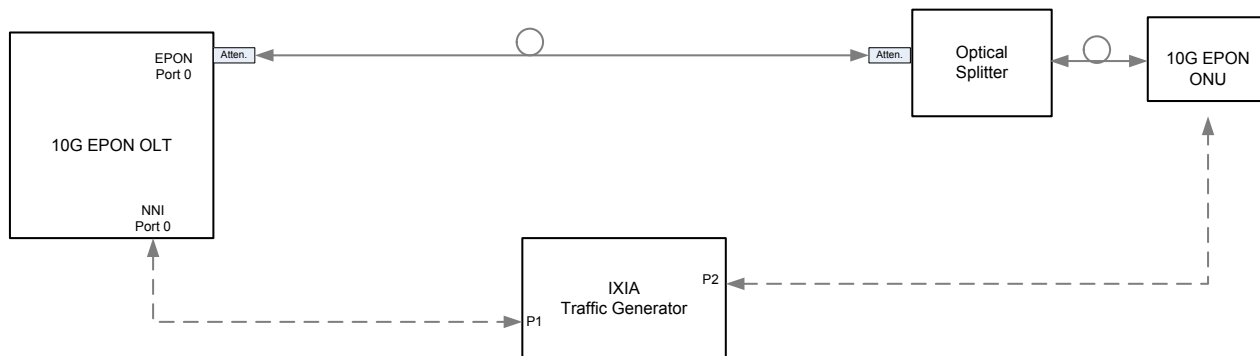



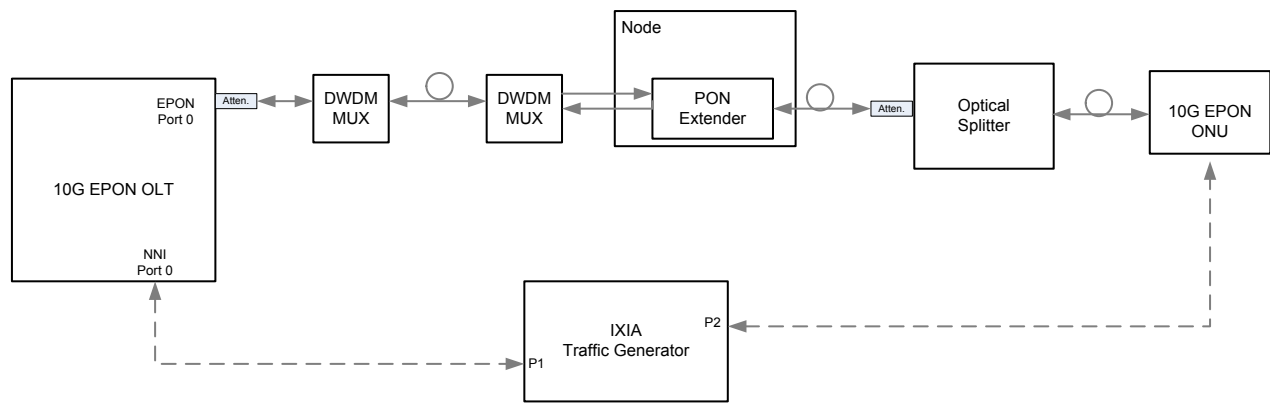

Figure 12 – Top: CAA – OLT with Standard Wavelengths  
Bottom: CAA – OLT with PON Extender

We then kept the ODN distance to 2 km and increased the OLT trunk distance from 20 to 80 km for different traffic loads to measure the throughput, delay, and jitter performance. We also tested the system with unsolicited scheduler (e.g. UGS), which is available today in widely used EPON chips for both ONUs and OLTs. The DPoE system does not prevent the use of UGS schemes, but the current standard does not define its configuration and dynamic UGS SF provisioning. As also stated in SIEPON specifications unsolicited scheduling is suitable for mobile backhaul type applications; this may depend on the PON reach and split architecture. It may be also used efficiently for other traffic cases if the appropriate configuration can be supported. For all distances we tested, maximum achievable UGS throughput was measured with no degradation due to PON Extender to show the impact of increased RTT on the DBA.

For the 40 km OLT distance and 2 km ODN distance, the packet captures from an Ixia traffic generator and the OLT and ONU statistics are analyzed. When UGS scheduler is applied (with length 30720/35412 TQ and interval of 30720 TQ for a fixed packet size of 1460 bytes IP packet and 20 bytes of IPG and preamble overhead), we can observe that  $30720 * 20 / 1480 = 415$  packet bursts are transmitted every  $\sim 0.000566$  seconds which is the transmission duration of the burst over the link with 8.7Gbps effective throughput). Higher inter-packet delays in Figure 13 define the unsolicited scheduler burst boundaries. This test and other tests done at different distances and system parameters show that PON extender itself does not introduce any degrading delay and/or jitter (Figure 13).

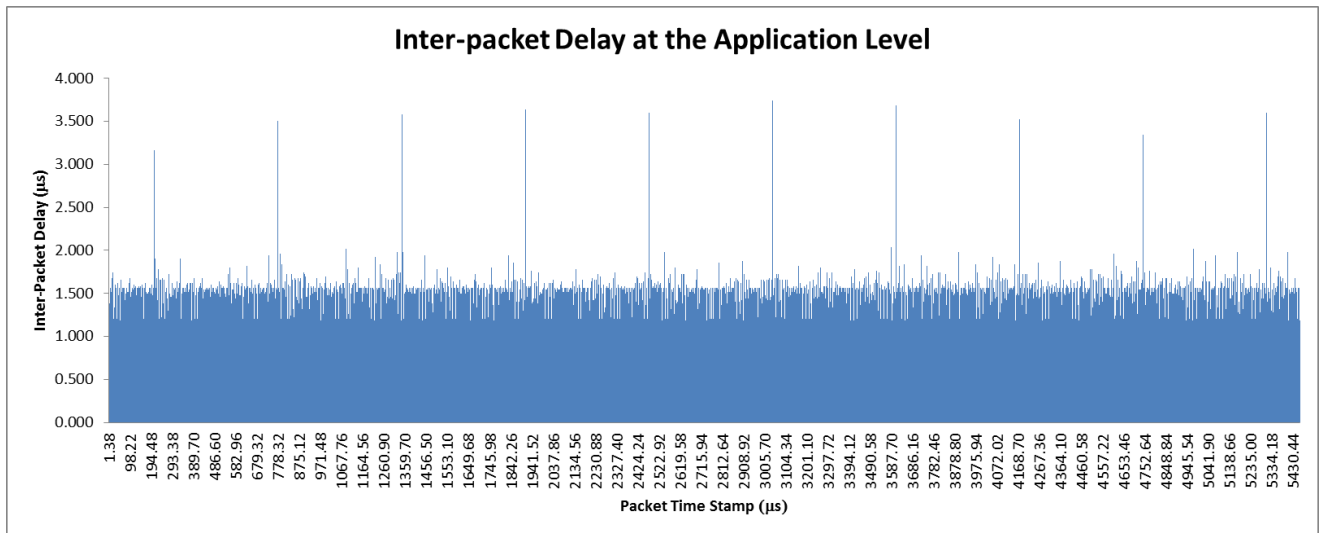

Figure 13 – Inter-packet Delay measured at the traffic generator receive port for UGS scheduler

When we tested the system with original DBA algorithm, we observed ~6.8 Gbps for the given system parameters (i.e. token size and report threshold of 16384 TQ and no rate shaping). Statistics at the traffic generator, ONU and OLT show that packets are dropped at the ONU link queue with maximum size of 1020kB due to increased waiting time (Figure 14, maximum inter-packet delay measured was ~250 $\mu$ s). All other packets are transmitted correctly over the EPON link. We then tested an algorithm that increases the accuracy of grant by taking into account the delay introduced by measured RTT and were

able to increase the throughput by more than 1 Gbps (Figure 15). Our preliminary test configurations are made to achieve maximum efficiency levels to isolate the issues while depending on the number of LLIDs and traffic characteristics the performance of different schedulers may change. Our ongoing work will continue to focus on increasing the efficiency of scheduler over the long reach PON cases by considering different distance and split architectures and traffic requirements.

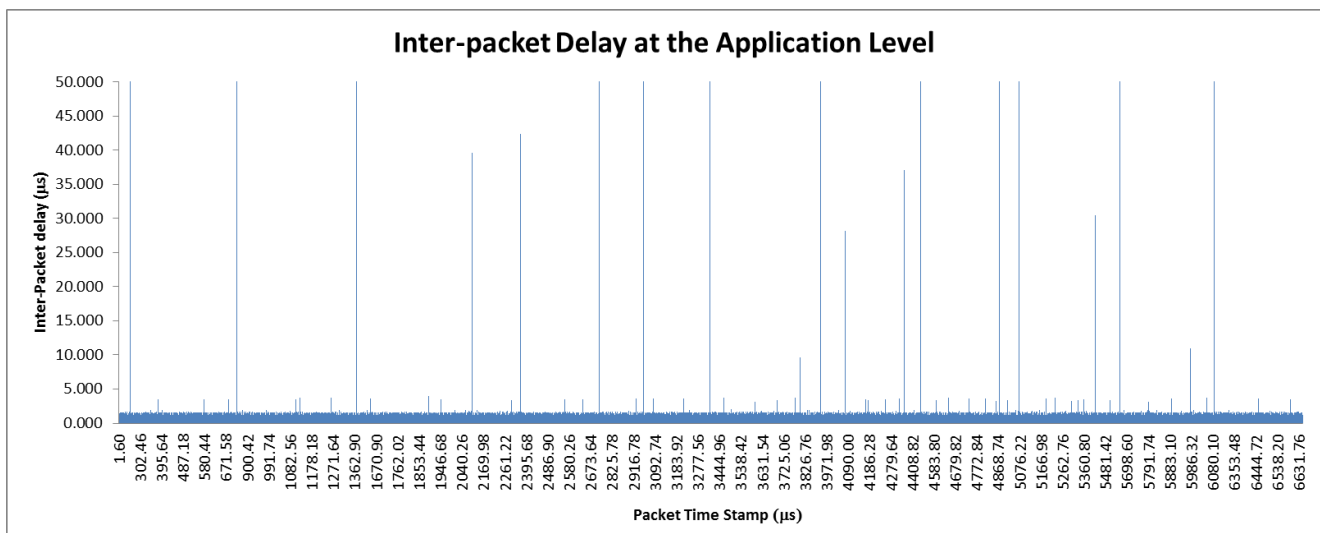

Figure 14 – Inter-packet Delay Measured at the Traffic Generator Receive Port for the Solicited DBA Scheduler

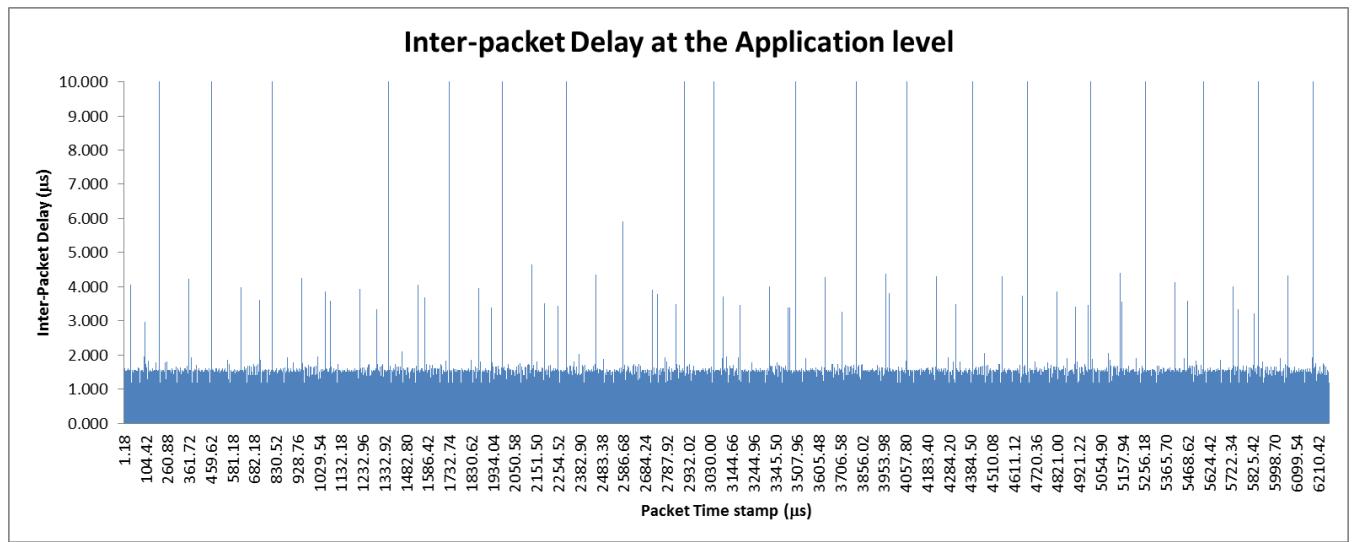

Figure 15 – Inter-packet Delay Measured at the Traffic Generator Receive Port for the Modified Solicited DBA Scheduler

**Pros:**

- **Location of DPoE subsystem hardware:** 95% in the conditioned facility (PON optics in remote device)
- **Location of DPoE subsystem software:** 100% in the conditioned facility
- **SDN Architecture Support:** Yes Completely
- **NFV Architecture Support:** Yes Completely
- **Plant Actives:** less complex than all DAA solutions
- **Plant Power:** less power than all DAA solutions
- **Plant Space:** less space than all DAA solutions
- **Solves Fiber Utilization:** using WDM at the OLT solves fiber utilization challenge of traditional PON and enabling service providers to leverage the fiber they already have between facility and node serving area.
- **Solves Serving Area Distance:** will cover nearly the entire MSO market up to about 80 km limit (Depending on the subscriber and traffic requirements)

- **Solves Facility Consolidation:** allows massive headend consolidation perhaps distances of 80 km could be reached
- **Solves Facility Space/Power:**
  - Same space is needed in Non-blocking architecture vs. RPM
  - Little more space is needed in Non-blocking architecture vs. R-OLT and RDS
  - Overall there may not be a massive space saving of PON Extender vs. the DAA approaches
- **Solves Cost Per Customer:** CAA PON Extender increases subs to 64-128 per port thus decreasing costs per sub in fiber spans 5-10km from the PON extender
- **Solves ONU Optics:** All CPE use same optics and can be least costly version but depend on split ratio
- **Operations MTTD/MTTR:** higher than passive ODN but less than any of the distributed access architecture.

**Cons:**

- **Plant Space/Power:** Actives require batteries, electricity, and maintenance forever
- **Facility Space/Power:**
  - PON Extender cannot oversubscribe the 10G link between facility and node
  - Depending on oversubscription ratio there could be a little space increase
- **Capacity and Latency Performance Differences:** The PON extender allows the distance between the OLT and ONUs to expand longer than typical PON networks of less than 20km. The “current” upstream OLT scheduler was not designed for long distances between PON upstream scheduler and the ONUs. Currently as the distance expands between the OLT scheduler and the ONU link capacity will decline, this is not a PON extender architecture issue. The industry is developing methods to improve capacity levels. Some service providers may find sufficient upstream capacity exists and the reduction is worth not placing PON OLT hardware and software in the remote device (node or cabinet)
- **Cost Per Customer:** The PON extender has a 1:1 mapping from the OLT port in the facility across the trunk fiber to the PON extender node (known as the 10G Ethernet trunk link) and this is mapped to a 10G EPON Optic line link to the customers. The trunk link between the facility and PON extender may not be shared with multiple 10G EPON Optic line links, known as oversubscription of the trunk link. The PON extender improves the economics in some CAA architectures, but when compared to the DAA approaches which all can oversubscribe the 10G Ethernet trunk link, such as having more 10G EPON line link capacity then 10G Ethernet trunk line capacity the cost per customer can be a bit higher “if” oversubscription of the trunk

link is used by the DAA approaches. Oversubscribing the trunk link is like oversubscribing the backplane lanes or having a blocking architecture. Generally most service providers prefer to have non-blocking backplane architecture between 10G EPON client cards and the fabric / WAN modules.

- **Number of Optical Ports in the Access Layer:** 2 additional Optics (10G Ethernet OLT & NNI at PON Extender Node)

### Assessment

PON Extender is an active component in the outside plant making the solution Active Optical Network (PON moves to AON). The distance may support up to 80 km between DPoE System and PON Extender and another 20 km to the customer, depending on the split ratio, wavelength usage (MUX/DEMUX loss) and throughput/delay requirements. The use of WDM optics between the headend and the node improves the fiber utilization significantly. Furthermore, higher split ratio maximizes the PON port utilization. CPE uses the same 10G EPON 802.3av optical wavelengths but with a more relaxed requirement set compared to all passive CAA solutions. The throughput and delay improvements are ongoing work.

### DAA – Remote PON MAC (RPM)

The Remote PON MAC (RPM) access architecture splits the OLT functions in two parts. The Modular Optical Line Terminal (M-OLT) Packet Shelf contains all of the downstream traffic management functions and upstream upper traffic management functions.

If we consider that the DPoE subsystem, shown in Figure 5 contained a box called OLT, this architecture splits the OLT function in two pieces. The EPON MAC functions for the downstream and upstream as well as a

portion of the upstream traffic management functions are placed in the Remote PON MAC (RPM), this could be a node or cabinet form factor. In this architecture the majority of the software and packet processing are handled at the facility and in this case the M-OLT Packet Shelf, but this could be cloud based systems. The M-OLT in this system

architecture contains the functions of DPoE mediation as well as management of the perhaps hundreds of RPMs in the field. In many ways the RPM is an extension of the I-DPoE Systems in that is extending the PON MAC and port from the line card to the node location.

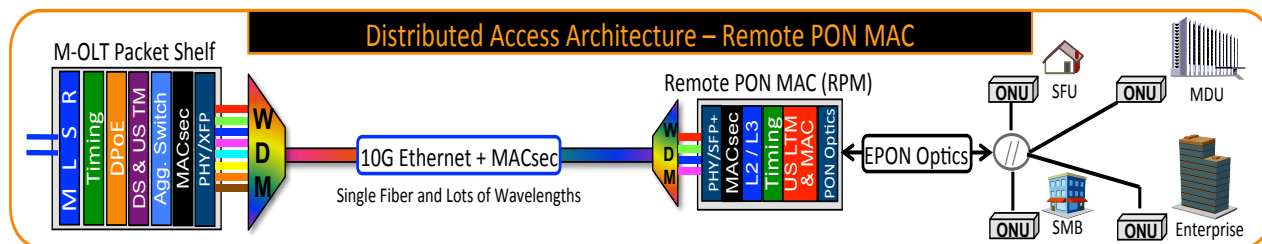

Figure 16 – DAA – Remote PON MAC (RPM)

**Pros:**

- **Location of DPoE subsystem hardware:** 90% in the conditioned facility (PON MAC, Optics, and basic L2 in then remote device)
- **Location of DPoE subsystem software:** 95% in the conditioned facility
- **SDN Architecture Support:** Yes
- **NFV Architecture Support:** Yes (except for MAC and Upstream lower Traffic Management)
- **Plant Actives:** less complex than R-OLT and RDS solutions
- **Plant Power:** less power than R-OLT and RDS solutions
- **Plant Space:** less space than R-OLT and RDS solutions
- **Solves Fiber Utilization:** using WDM at the OLT solves fiber utilization challenge of traditional PON and enabling service providers to leverage the fiber they already have between facility and node serving area
- **Solves Serving Area Distance:** There is no distance limit because of the DPoE subsystems in the facility and the remote device.

- **Solves Facility Consolidation:** allows massive headend consolidation
- **Solves Facility Space/Power:**
  - Supports oversubscription of the 10G node trunk uplink allowing for greater sub per link and less headend space
  - Requires a little more space in Non-blocking architecture vs. R-OLT and RDS
- **Solves Cost Per Customer:**
  - Increases subs to 64-128 per port non-blocking
  - Costs improve with oversubscribed uplink increasing subs per facility port
- **Solves ONU Optics:** All CPE use same optics and can be least costly version but depend on split ratio.

**Cons:**

- **Operations MTTD/MTTR:** higher than passive ODN and higher than PON Extender (likely lower than R-OLT and RDS)
- **Number of Optical Ports in the Access Layer:** 2 additional Optics (10G Ethernet OLT & NNI at PON Node)

- **Facility Space/Power:**
  - No or little space savings for Non-blocking RPM vs. PON Extender
  - R-OLT and RDS architectures will enable slightly increased space savings if oversubscription is used

**Assessment**

The RPM architecture allows the PON MAC and scheduler to be placed in the node or cabinet location. This allows for low latency and high capacity because the MAC is near the subscriber location. Additionally, this architecture will allow the service provider to enable several 10G PONs to different service areas, perhaps 4 groups of 128 subscribers could be supported. The RPM architecture like any of the DAA for PON solution has the flexibility to have the PON customer share the 10G Ethernet node uplinks ports.

This is a differentiation between PON extender and the DAA approaches. A service provider may elect not share the node up links ports between several PON port and just configure a non-blocking architecture, ensuring that a 10G PON port will have a 10G Ethernet uplink port. Many service providers around the world required non-blocking client card capacity across the backplane of a system. The remote PON architectures are really just remote port or remote line cards, and some carriers do not want to manage capacity and blocking. This approach places the least amount of DPoE subsystems

functions in the node in terms of hardware and software.

DAA – Remote OLT (R-OLT)

The remote OLT access architecture places the entire OLT functions in the remote device, including the PON MAC as well as most of the PON upstream and downstream traffic management functions. The R-OLT architecture does not place all of the DPoE subsystem functions in the node, most particularly the DPoE mediation layer functions handling the northbound provisioning system interfaces and vCM. The southbound interface we are suggesting a thin DPoE management client for control plane communications with the local functional blocks.

This architecture also introduces an element management system (EMS) to manage the five core areas of the Telecommunications Management Network (TMN) model key functions of fault, configuration, accounting, performance and security (FCAPS). The northbound EMS interfaces to network management systems SNMP, CLI, IPDR, authentication and access, and inventory systems. There is an ongoing work to define YANG models with NETCONF protocols to configure/manage remote devices. The southbound interfaces communicate with remote OLT network elements. This may also apply to RPM architecture for MAC and US LTM and other functionality in the node.

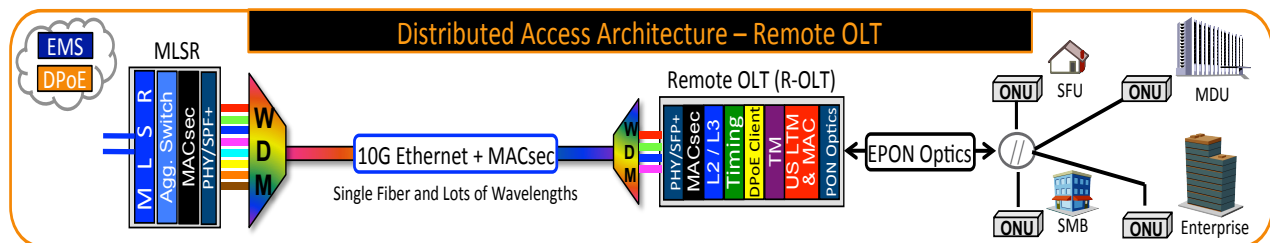

Figure 17 – DAA – Remote Optical Line Terminal (Remote - OLT)

**Pros:**

- **SDN Architecture Support:** Yes
- **NFV Architecture Support:** Yes (Routing and advanced Layer 2 subsystem only)
- **Solves Fiber Utilization:** using WDM at the OLT solves fiber utilization challenge of traditional PON and enabling service providers to leverage the fiber they already have between facility and node serving area
- **Solves Serving Area Distance:** There is no distance limit because of the DPoE subsystems in the facility and the remote device.
- **Solves Facility Consolidation:** allows massive headend consolidation
- **Solves Cost Per Customer:**
  - Increases subs to 64-128 per port non-blocking
  - Costs improve with oversubscribed trunk uplink increasing subs per facility port
- **Solves ONU Optics:** All CPE use same optics and can be least costly version but depend on split ratio
- **Solves Facility Space and Power:** The requirement for CWDM and DWDM optics in the MLSP aggregation device as shown in the architecture may not yield significant space savings compared to Remote PON MAC

**Cons:**

- **Location of DPoE subsystem hardware:** 50% in the field unconditioned environment
- **Location of DPoE subsystem software:** 50% in the field unconditioned environment
- **NFV Architecture Support:** The PON MAC, Upstream Lower Traffic Management, Upstream Upper Traffic Management, and Downstream Traffic

Management are in the remote device and cannot be part of NFV.

- **Operations MTTD/MTTR:** higher than passive ODN and higher than PON Extender
- **Plant Actives:** more complex than PON Extender and Remote PON MAC
- **Plant Power:** more power than PON Extender and Remote PON MAC
- **Plant Space:** likely more than PON Extender and Remote PON MAC
- **Number of Optical Ports in the Access Layer:** 2 additional Optics (10G Ethernet OLT & NNI at PON Node)

**Assessment**

The remote OLT is often used to describe the placement of PON functions in the node and as this paper illustrates there can be a vast range of functions that could be placed in the node. The reason why this architecture, and not any other, is referred to as remote OLT is because the entire OLT subsystem in the DPoE reference architecture is placed in the node location. This includes the PON MAC, upstream traffic management and downstream traffic management functions.

This does not include the full DPoE mediation layer software functions, so this could not be called a Remote DPoE system as shown below. The placement of the PON MAC and traffic management layer functions requires more software in the remote location. Additionally the DPoE mediation layer systems are split to manage the southbound interfaces to the MAC, TM, and switching functions and the northbound and virtual cable modem functions are located in the facility. Additionally, to scale the remote OLT will need an element management system (EMS). The functions of hardware and software are split.



## DAA – Remote DPoE System (RDS)

The Remote DPoE System (RDS) access architecture places the entire DPoE system functions in the remote device. This architecture also introduces an element management system (EMS) to manage the five core areas of the Telecommunications Management Network (TMN) model key

functions of fault, configuration, accounting, performance, and security (FCAPS). The northbound EMS interfaces to network management systems SNMP, CLI, IPDR, authentication and access, and inventory systems. There is an ongoing work to define YANG models with NETCONF protocols to configure/manage remote devices.

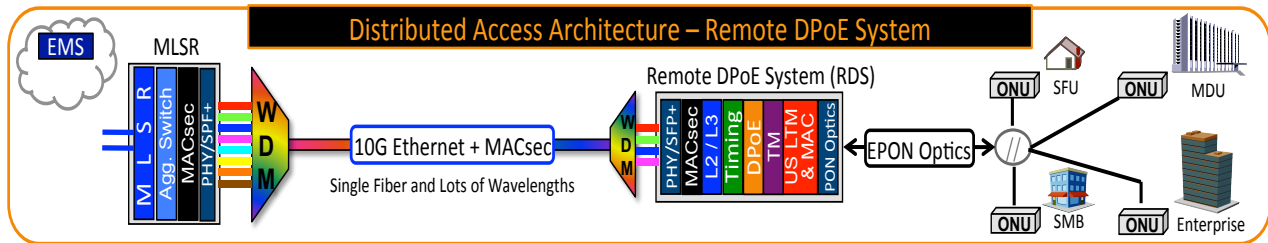

Figure 18 – DAA – Remote DPoE System (RDS)

### Pros:

- **Location of DPoE subsystem software:** All of the DPoE subsystems software are together thus reducing the system complexity and trouble shooting
- **SDN/NFV Architecture Support:** Yes
- **Solves Fiber Utilization:** using WDM at the OLT solves fiber utilization challenge of traditional PON and enabling service providers to leverage the fiber they already have between facility and node serving area
- **Solves Serving Area Distance:** There is no distance limit because of the DPoE subsystems in the facility and the remote device.
- **Solves Facility Consolidation:** allows massive headend consolidation
- **Solves Cost Per Customer:**
  - Increases subs to 64-128 per port non-blocking
  - Costs improve with oversubscribed trunk uplink increasing subs per facility port
- **Solves ONU Optics:** All CPE use same optics and can be least costly version but depend on split ratio

- **Solves Facility Space and Power:** The requirement for CWDM and DWDM optics in the MLSR aggregation device as shown in the architecture may not yield significant space savings compared to Remote PON MAC

### Cons:

- **Location of DPoE subsystem hardware:** As high as 100% in the field unconditioned environment, but at minimum PON MAC/PHY, upstream and downstream traffic management, DPoE mediation layer, and Layer 2 switching.
- **Location of DPoE subsystem software:** As high as 100% in the field unconditioned environment (assuming all of the routing, advanced L2 functions, VSI, and VPN encapsulation function take place in the remote device) At minimum PON MAC/PHY, upstream and downstream traffic management, DPoE mediation layer, and Layer 2 switching.
- **NFV Architecture Support:** In some Remote DPoE Systems architectures none of the subsystem could be part of NFV. At minimum the PON MAC, Upstream



Lower Traffic Management, Upstream Upper Traffic Management, and Downstream Traffic Management are in the remote device and cannot be part of NFV.

- **Operations MTTD/MTTR:** higher than passive ODN and higher than PON Extender
- **Plant Actives:** more complex than PON Extender and Remote PON MAC
- **Plant Power:** more power than PON Extender and Remote PON MAC
- **Plant Space:** likely more than PON Extender and Remote PON MAC
- **Number of Optical Ports in the Access Layer:** 2 additional Optics (10G Ethernet OLT & NNI at PON Node)

## Assessment

The integrated Remote DPoE system is a self-contained platform with all or nearly all of the subsystem supported in the device. The major DPoE subsystems including the MAC, traffic managements, DPoE mediation layer software, vCM, layer 2, layer 3, VSI, and MPLS PE functions. The integrated remote DPoE system contains the mediation layer software. The standalone systems reduces the software complexity because like the I-DPoE System in the hub that contains all of the subsystem functions this can be easier to troubleshoot.

### DATA LINK ENCRYPTION BETWEEN SERVICE PROVIDER FACILITY AND THE REMOTE PON DEVICE

We are proposing a new data link encryption requirement between access network component at the edge of the trusted network, such as the M-OLT or switch/router, and the remote PON device, such as the

remote PON MAC, remote OLT, or remote DPoE System. This paper suggests that the DAA for PON approach should align with the CableLabs Remote PHY and Remote MAC-PHY specifications for data link encryption and authentication between the remote devices, which is based on MACsec, as defined in IEEE standard 802.1AE MAC Security. The link between the service provider's facility and the remote PON device is referred to as the trunk link or the uplink. This link is where our newly proposed data link encryption and authentication needs to be defined and accepted by the industry.

The remote PON device must be authenticated and authorized, while the control/management plane must be secured. The 802.1X authentication using EAP between the Remote Device (supplicant) and network access port of the switch/router or M-OLT (authenticator) may be implemented. In this case, Authentication Server has the security credentials and communicates with EAP messages with the authenticator. MACsec may provide additional security that defines a virtual port for each connected physical port of remote device. The MKA (802.1x) key management algorithm is used for the exchange of encryption keys (e.g. AES128 based encryption). MACsec is a Layer 2 and hop-by-hop security protocol.

The implementation simplicity and high throughput capability makes MACsec preferable for data link security. The DAA for PON figures used in this paper illustrate a MACsec subsystem, which is part of the M-OLT PS and also part of a multilayer switch router (MLSR) both in the trusted network. In all cases the remote PON devices in the untrusted network also has a MACsec subsystem. If the M-OLT does not have the MACsec subsystem or if it was not directly connected to the Remote PON MAC device, a switch/router enabled with MACsec would be used to enable secure communications.

The PON link security between the OLT subsystem and ONUs is defined in the DPoEv2 and/or the SIEPON security specifications and remains unchanged in this proposal. These include DPoE 10G - AES 128 Counter Mode (CTR) in downstream only or bidirectional methods are available. MKA (802.1X) is used for key exchange when MACsec is implemented for bidirectional encryption. Due to data link encryption and authentication already being defined between the OLT and the ONU, none CAA for PON approaches need additional requirements; this applies to PON extender as well. In addition, the DPoE System/controller must provide secure provisioning and management of the Remote Device.

## SUMMARIES AND CONSIDERATIONS

The architectures defined and reviewed in this paper have many trade-offs and considerations for the service provider. The service provider will have specific technology constraints that may limit the selection of the architecture. These architectures represent the next generation of DPoE systems and subsystems. There are several new subsystems as well as communication methods that will need to be determined and defined by the industry. These may include wavelength management for the Multi-wave DPoE 10G System, MACsec for communications with remote PON nodes and cabinets, new communication methods for provision and managing remote subsystems, timing, and more.

In Figure 19, this is meant to summarize the location of the hardware and software functions. The placement of the hardware and

software functions may also determine the future SDN and NFV possibilities. In the SDN architecture design the control plane processes may be separated and placed on servers and the data plane may be on purpose built systems, in the table below this describes the possible locations. Additionally, using Network Function Virtualization (NFV) architecture design both control and data plane processes may be placed on servers and traffic through spine switches.

If NFV is planned, then the service provider could examine the table below to determine which architecture aligns with their vision. If the service provider believes that over time all of the DPoE subsystems could be virtualized, then staying to the left side of the table is best, because these systems are not placed in the field but rather facilities to be far easily swapped out. If little or none of the data plane functions are planned to be virtualized then investing in any of the approaches is fine.

The final figure listed at the bottom of this paper is a summary assessment of the different CAA and DAA options. The figure shows that the Remote DPoE System (RDS) has all of the major subsystem functions in the remote device, including the DPoE mediation layer software. As with the hub based DPoE subsystems some Layer 2 and advanced routing and MPLS may be inside the DPoE system or in an external device. Figure 19, uses the term optional with regards to the location may be at the facility or the node/remote device.

Location of Hardware and Software Functions	10G EPON OLT with Standard Wavelengths	10G EPON OLT with NG-PON2 Wavelengths	PON Extender	Remote PON MAC (RPM)	Remote OLT (R-OLT)	Remote DPoE System (RDS)
Element Mgmt. Sys (EMS), Controller, AGM	Facility	Facility	Facility	Facility	Facility	Facility
L3VPNs MPLS L3	Facility	Facility	Facility	Facility	Facility	Optional
L2VPNs VPWS/VPLS with MPLS Encapsulation	Facility	Facility	Facility	Facility	Facility	Optional
Advanced L2 Virtual Switching Instance (VSI)	Facility	Facility	Facility	Facility	Facility	Optional
Advanced L2 802.1ah (MAC-in-MAC)	Facility	Facility	Facility	Facility	Facility	Optional
Routing Protocols (BGP, OSPF, IS-IS, BFD)	Facility	Facility	Facility	Facility	Facility	Optional
DPoE Mediation Layer Functions	Facility	Facility	Facility	Facility	Facility	Node
MACsec (802.1ae) facility & remote	N/A	N/A	N/A	Facility & Node	Facility & Node	Facility & Node
NNI and PON Interface ACL (ingress & egress)	Facility	Facility	Facility	Facility & Node	Facility & Node	Node
Layer 3 Aware (DHCP Relay)	Facility	Facility	Facility	Facility & Node	Facility & Node	Node
Layer 2 Switch with Multicast & Link Agg	Facility	Facility	Facility	Facility & Node	Facility & Node	Node
Downstream Traffic Management (DS TM)	Facility	Facility	Facility	Facility	Node	Node
Upstream Upper Traffic Management (US UTM)	Facility	Facility	Facility	Facility	Node	Node
Upstream Lower Traffic Management (US LTM) Scheduling / Shaping Algorithms / QoS	Facility	Facility	Facility	Node	Node	Node
PON MAC/PHY (Report/Gate/LLID/FEC)	Facility	Facility	Facility	Node	Node	Node
10G EPON Optics (PMD layer)	Facility	Facility	Node	Node	Node	Node
PON MACsec (802.1ae) OLT & ONU	Facility & CPE	Facility & CPE	Facility & CPE	Node & CPE	Node & CPE	Node & CPE

*Figure 19 – Locations of CAA and DAA DPoE System Functions*

Figure 20, provides a summary comparison of the different architectures. In the area of reliability and operational complexity, the CAA options have no active or an active with minimal complexity (PON Extender), therefore reliability of the OSP is high.

The DAA options introduce new software and hardware in the plant, which introduces new reliability issues that require new redundancy features. Note that the failure of a remote device will impact only a small base of subscribers, and both the failure detection

and recovery may be faster, if these systems have diverse fiber paths to redundant aggregation systems. The Remote DPoE System (RDS) has the minimum dependency on the other system components. However to scale the systems an EMS is likely needed as well as development for field support engineers to troubleshoot.

Areas	10G EPON OLT with Standard Wavelengths	10G EPON OLT with NG-PON2 Wavelengths	PON Extender	Remote PON MAC (RPM)	Remote OLT (R-OLT)	Remote DPoE System (RDS)
Location of DPoE subsystem hardware	Facility Only	Facility Only	Facility except PON optics	Facility except Basic L2, PON MAC, & PON optics	90% in the field	100% in the field
Location of DPoE subsystem software:	Facility Only	Facility Only	Facility Only	95% in the Facility	90% in the field	100% in the field
SDN Future Architecture Support:	Yes	Yes	Yes	Yes	Yes	Yes
NFV Future Architecture Support:	Yes - Completely	Yes - Completely	Yes - Completely	Yes - Except MAC & Some Upstream TM	Only Routing subsystem only	No DPoE Subsystems or limited
Plant Actives:	None	None	Low	Medium	High	High
Plant Power:	None	None	Low	Medium	High	High
Plant Space:	None	None	Low	Medium	High	High
Fiber Utilization:	1 (Poor)	8 or more	16+	16+	16+	16+
Serving Area Distance:	10km – 20km	20km – 40km	Up to 80km + 20km	No Limit to node 20km to ONUs	No Limit to node 20km to ONUs	No Limit to node 20km to ONUs
Facility Consolidation:	Limit to 20 km	Limit to 40 km	Up to 80km + 20km	No Limit to node 20km to ONUs	No Limit to node 20km to ONUs	No Limit to node 20km to ONUs
Facility Space / Power (assuming non blocking architecture and 128 split is possible for PON Extender and 10G Ethernet RPM, R-OLT & RDS):	64 subs 10km (2X) 32 subs 20km (4X)	128 subs 10km (same) 64 subs 20km (2X) 32 subs 40km (4X)	128 per PON port - No oversubscription of uplink possible	128, 256, or 512 Subs Possible per 10G Ethernet port	128, 256, or 512 Subs Possible per 10G Ethernet port	128, 256, or 512 Subs Possible per 10G Ethernet port
Cost Per Customer:	64 subs competitive vs. 128 PON Ext	Highest Capital Cost	128 subs per port is best case	Lowest cost with oversubscription	Lowest cost with oversubscription	Lowest cost with oversubscription
ONU optics:	Low Cost but same wave	Highest Cost but different waves	Lowest Cost but the same wave	Lowest Cost but the same wave	Lowest Cost but the same wave	Lowest Cost but the same wave
Number of Optical Ports in the Access Layer:	1	1	3	3	3	3
Data Traffic Encryption 10G Ethernet Segment	N/A	N/A	Uses existing OLT to ONU security	Proposed MACsec	Proposed MACsec	Proposed MACsec
Latency Performance Delta (vs. Standard OLT)	N/A	None	Variable Impact	None	None	None
Capacity Performance Delta (vs. Standard OLT)	N/A	None	Variable Impact	None	None	None
System Complexity (Software Architecture)	Low	Low	Low	Medium	High	Low
Operational Complexity (MTTD/MTTR)	Low	Low	Low	Medium	Highest	High
Reliability or MTBF Assessment	Highest	Highest	High	Medium	Low	Low
Supported by Existing OSP System Technicians	Yes	Yes	Yes	Marginal Increase	Different Skill Set	Different Skill Set

Figure 20 – Summary Assessment of CAA and DAA DPoE System

## **Centralized Access Architecture – OLT with NG-PON2 Wavelengths**

- This may reduce the application for PON Extender and remote OLT due to:
  - The main driver for PON Extenders or remote OLT is fiber conservation (use of WDM between Facility and Node this approach eliminates that driver)
- Major Challenges:
  - Costs will increase at the OLT and ONU compared to nearly all other solutions
    - Aligning 10G EPON TWDM and NG-PON2 TWDM will drive volumes and will reduce cost
    - Cost will likely not reach the 10G EPON single wave level
    - We are exploring many different CPE optical wavelength plans and non-tunable solutions (should reduce costs)
  - Full Band Tunable Optics increase the one-time capital cost of the solution but yields an all passive network for operations
  - Partial band Tunable or Single Wave may reduce capital but will impact operations due to management of different colored pluggables or CPE
  - Capital costs are the major problem of this solution

## **Summary Assessment of CAA for PON Extender:**

- Requires active in the outside plant (PON moves to AON – Active Optical Network)
- Use of WDM optics to the PON extender node for fiber utilization
- Extends distance to ~80 km
- Maximizes PON port utilization

- Maintains the use of the same 10G EPON 802.3av PON optical wavelengths to the CPE
- Costs compared to CAA PON and DAA need to be examined closely

## **Summary Assessment of DAA for PON:**

- The functions required/desired in the Remote PON Device shifts complexity and costs
- Requires actives in the outside plant (PON moves to AON – Active Optical Network)
- Maximizes fiber utilization with use of WDM optics to the DAA for PON device
- Maximizes fiber distance between facility and customers served to ~80 km or more
- Maximizes PON port utilization because PON closer to subs (parity with CAA PON Extender)
- Space Savings in the headend (depends and may not be significant)
- Depends on customers per headend aggregation router port (within 2 km allows 128 subs per port)
- If non-blocking between headend and node is desired this may have marginal headend space savings (vs. PON Extender)
- Preference for blocking between headend and node may have significant space savings but with required intelligence in the ODN and potential blocking during peak periods
- Maintains the use of the same 10G EPON 802.3av PON optical wavelengths to the CPE
- Costs compared to CAA PON and PON Extender needs to be examined closely

## **ACKNOWLEDGEMENTS**

The authors would like to thank the following individuals and test teams: Janet Bean, Allen Hui, Anand KumarGoenka, Wichai Wongchaisuwat, Tony Cotter, Greg Cyr, Tom Ferreira and Dave Hartrum.

## REFERENCES

[CableLabs] DOCSIS® Provisioning of EPON Specifications DPoEv2.0 DPoE Architecture Specification DPoE-SP-ARCHv2.0-I04-150611

[IEEE] IEEE 802.3av-2009 Standard