

# DVB-C2 – THE SECOND GENERATION TRANSMISSION TECHNOLOGY FOR BROADBAND CABLE

Philipp Hasse, Dirk Jaeger, Joerg Robert  
Institut fuer Nachrichtentechnik at Technische Universitaet Braunschweig

## Abstract

*Competition in the media and communication sector is increasing. MSOs have to align their business models with new emerging requirements on a permanent basis. Although requirements vary in different national markets in Europe and worldwide, the cost per transmitted bit is an important factor for staying competitive. Thus one of the key requirements for modern communication technologies defined by European MSOs is to increase the spectral efficiency of downstream transmissions by moving the efficiency as close as possible to the Shannon limit – the theoretical optimum.*

*The second generation of the DVB system for cable – called DVB-C2 – is an innovative approach making use of state of the art communication technologies which have never been implemented in broadband cable networks before. An OFDM (Orthogonal Frequency Division Multiplex) based modulation scheme in combination with a two-dimensional interleaving (in both frequency and time) and an LDPC (Low Parity Density Code) error protection mechanism provide a spectral efficiency fractions of a dB below the Shannon limit. Will there ever be any reason to develop a new PHY for cable after DVB-C2 is widely implemented?*

## INTRODUCTION

The Digital Video Broadcasting (DVB) transmission system for cable (DVB-C) [1] defines physical layer and low-layer signaling techniques for the transmission of digital

broadcasting services via cable networks. The technology was also incorporated in the European version of DOCSIS [2]. Since its development more than 10 years ago, DVB-C has been commercially implemented in millions of products such as (Edge)QAMs, set tops, and cable modems all over the world.

During the recent 10 years, research in communications techniques has progressed. State of the art algorithms have improved significantly in terms of performance and flexibility and Moore's law has continued to happen. These trends have facilitated the commercialization of advanced systems for wireless and wire-line communication.

Forced by the increasing competition in the media and communications sector, European MSOs considered utilizing the benefits provided by such modern communication technologies in broadband cable networks. In 2006, the DVB [3] Project was approached to launch a work item aiming at the development of a second generation DVB system for cable called DVB-C2.



Figure 1: Logos of DVB and ReDeSign

This article describes the DVB-internal development process of the DVB-C2 specification. It focuses on the work carried out by the DVB Technical Module and its TM-C2 technical experts group launched to prepare the technical specification. The DVB work is supported by the research project ReDeSign. The Institut fuer Nachrichtentechnik (IfN) of Technische Universitaet Braunschweig has taken key positions in both organizations,

DVB and ReDeSign. Furthermore IfN staff has been in charge of DVB work on dedicated DVB-C2 techniques such as signaling and synchronization and has made important contributions incorporated in the final specification.

### DVB AND REDESIGN

The development of DVB-C2 has involved some 20 companies including MSOs, IC manufacturers and equipment vendors. The chairmanship is provided by Kabel Deutschland, one of the major European MSOs. Based on a liaison agreement, the work is supported by the European research project ReDeSign [4] which has allocated considerable resources to the work. One of the tasks of the ReDeSign team is for instance to support the standardization work by means of computer simulations.

An initial Technology Study Mission executed among DVB member companies by the Technical Module confirmed the potential improvements achievable with latest communication technologies in cable. Prior to the technical work, use cases were studied and business requirements were defined by DVB's Commercial Module. Major requirements are summarized further down in the article. The technical work was kicked off by means of a Call for Technologies (CfT). The responses created the basis of the subsequent development of the DVB-C2 specification.

An important tool for the development of DVB-C2 has been the software simulation platform. The simulations focused on two goals: First to compile the final DVB-C2 system from individual elements of the responses to the CfT and secondly to execute performance simulations of the system. A cable channel model was adopted for this purpose [5]. The model was developed by the ReDeSign consortium. To a large extent, the channel model takes account of the results

derived during the work of IEEE 802.14 [6]. The non-linear behavior of digital signals, however, was researched in ReDeSign. Software models were developed incorporating the results of this work. As explained later, intensive investigations were necessary to generate the knowledge required for the creation of software tools modeling the statistical behavior of second and third order intermodulation products generated by multiple QAM signals.

### COMMERCIAL REQUIREMENTS

The DVB Commercial Requirements [7] constitute the fundament for the development of the technical solution. The major requirements are summarized as follows. DVB-C2 needs to provide:

- A toolkit solution for optimal implementation under all conceivable transmission conditions of various cable networks
- Increased spectral efficiency by at least 30 % compared with the highest efficiency provided by DVB-C
- Advantageous operational flexibility
- Support of removal of fixed cable channel rasters
- A low latency mode
- Adoption of state of the art technologies
- An integral solution of the DVB Family of Standards approach: reuse of elements of existing DVB standards (e.g. of DVB-S2 and DVB-T2), wherever appropriate
- Support for possible incorporation in DOCSIS
- Cost efficient production of cable devices such as set-tops but also of trans-modulators used in headends of SMATVs

It is worth mentioning that the issue of backwards compatibility with DVB-C was

sacrificed to the requirement of optimizing the spectral efficiency and thus the throughput of the new technology. 26 requirements and 5 exemplary use cases were defined in total.

### THE DVB-C2 TECHNOLOGY

The DVB-C2 specification (still in final draft stage) defines the signal processing at the transmitting end. The high-level block diagram is given in figure 2. Basically the signal processing comprises an input processing block, the multiple stages FEC unit and the OFDM generator.

#### Physical Layer Pipe (PLP)

The DVB-C2 system is intended to provide a transparent data link for all kinds of digital information. Data formats such as MPEG Transport Stream (TS) [8] and DVB Generic Stream Encapsulation (GSE) [9] specially designed to support the transport of IP data can be interfaced to the system. For enabling the transparent transmission, a PLP concept was defined. A PLP takes the role of a basic container utilized for the transport of the data. A PLP container can for instance comprise a multiple program Transport Stream, a single program, a single application, or any kind of IP based data. The data being inserted in a PLP container are converted into the DVB-C2 internal frame structure by the Data Input Processing Unit and subsequently processed by the FEC (Forward Error Correction) encoder. The FEC is composed of a Bose-Chaudhuri-Hocquenghem (BCH) outer Code [10] and a Low-Density-Parity-Check (LDPC) inner code [11]. The LDPC is a very powerful tool for correcting transmission errors whereas the BCH's task is to eliminate the error floor which may be produced by the LDPC decoder in the receiver under certain transmission conditions. The BCH code rates add less than 1 % redundancy. The LDPC code rates available range from 2/3 to 9/10. The FEC encoded data are mapped onto QAM

constellations which eventually will be assigned to the individual sub-carriers of the OFDM symbol. A number of QAM constellations are defined ranging from 16-QAM up to 4096-QAM. For each QAM constellation a dedicated set of LDPC code rates is selected. A combination of the modulation and coding parameters is called ModCod. The ModCods defined for DVB-C2 are listed in table 1. Adding a PLP header completes the creation of the PLP container.

|      | <i>16-QAM</i> | <i>64-QAM</i> | <i>256-QAM</i> | <i>1k-QAM</i> | <i>4k-QAM</i> |
|------|---------------|---------------|----------------|---------------|---------------|
| 9/10 | X             | X             | X              | X             | X             |
| 5/6  | X             | X             | X              | X             | X             |
| 3/4  | X             | X             | X              | X             |               |
| 2/3  |               | X             |                |               |               |

Table 1: ModCods of DVB-C2

#### Data Slice

Several PLPs may be combined to form a data slice whereas the protection power of the FEC assigned to each single container can be optimized individually by using an appropriate ModCod referred to above. The Data Slicer has the task to move the PLP container and group of containers, respectively, to a defined location within the bit stream in such a way that they will be transmitted by dedicated sub-carriers of the OFDM symbol and thus to appear at dedicated frequency sub-bands of the spectrum occupied by the OFDM symbol.

A two-dimensional interleaving (in time and frequency domain) is applied to each individual data slice in order to enable the receiver to eliminate impacts of burst impairments as well as of frequency selective interference such as single frequency ingress or possibly even by fading.

## OFDM frame builder

The OFDM frame builder combines several data slices together with auxiliary information and additional pilot sub-carriers. The pilot structure chosen is composed of continuous and scattered pilots. The continuous pilots are allocated at dedicated sub-carrier locations in each OFDM symbol, which are constant and do not vary between the symbols. The amplitudes of the pilots are boosted by a factor of 7/3 for improved robustness. A DVB-C2 receiver makes use of the 30 continuous pilots allocated per 6 MHz bandwidth to perform fine synchronization of the signal in frequency and time direction. By an averaging calculation of the continuous pilots, the common phase error caused by phase noise (induced e.g. in the RF frontend of the receiver) can be detected and compensated. After the synchronization is completed at the receiving end, the scattered pilots are used for channel equalization purposes. The inverse channel impulse response can easily be determined from the differing values between the received scattered pilots and their equivalent values transmitted known to the receiver.

Also the equalization process is easy for an OFDM system since a simple multiplication of each sub-carrier with an almost time-invariant factor can be applied rather than a complex convolution process needed in case of a single carrier solution. The number of scattered pilots is aligned with the length of the guard interval. 96 and 48 parts of all sub-carriers are used as scattered pilots in case the relative guard interval length equals to 1/128 and 1/64, respectively, of the symbol duration.

The auxiliary data referred to above contain mainly the so-called L1 (Layer 1) signaling information which is put in front of each OFDM frame in terms of a preamble. The preamble uses the complete set of sub-carriers of an OFDM symbol and provides the receiver with means required to access the PLPs. For instance, information about the start positions of the data slices within the OFDM frame is transmitted as well as the ModCod information of the PLP headers. Due to their importance, the PLP headers themselves are highly protected by means of robust modulation (e.g. QPSK or 16-QAM).

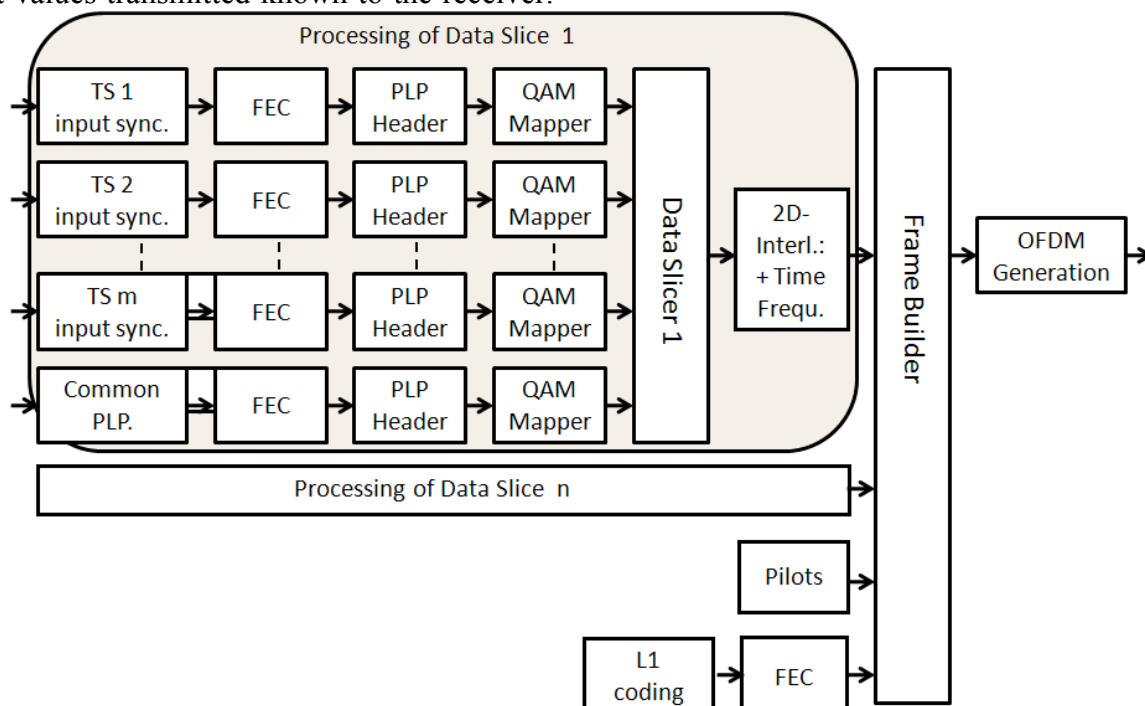

Figure 2: High-level block diagram of the DVB-C2 encoder

### OFDM generator

The OFDM symbols are generated by mean of an inverse Fast Fourier Transformation (IFFT). A 4K-IFFT algorithm is applied generating a total of 4096 sub-carriers, 3409 of which are actively used for the transmission of data and pilots within a frequency band of 6 MHz. These 3409 active sub-carriers occupy some 5.7 MHz. The sub-carrier spacing calculates to 1,672 Hz which corresponds with an OFDM symbol duration of 598  $\mu$ s. For markets employing 8 MHz channels such as the one in Europe, the entire system can easily be scaled up by a factor of 4/3 which results in a sub-carrier spacing of 2,232 Hz and a symbol duration of 448  $\mu$ s. The OFDM signal injected in an 8 MHz channel occupies a bandwidth of 7.6 MHz. The guard interval used between the OFDM symbols has a relative length of either 1/128 or 1/64 compared to the symbol length itself and thus durations of 4.7  $\mu$ s in the US respective 3.5  $\mu$ s in Europe.

### DVB-C2 FEATURES

The OFDM based concept implemented in DVB-C2 provides a couple of benefits in terms of flexibility as well as of efficiency advantages against single carrier solutions. Some of these benefits are introduced in the following sections.

#### Channel assembly at physical layer

The DVB-C2 system supports the feature of flexible and dynamic bandwidth allocation to individual data slices as well as to the entire signal. It is for instance feasible to combine various adjacent channels at physical layer in a very effective manner. Note that the term channel bonding was deliberately not used in this context in order to prevent confusion with the DOCSIS 3.0 feature of channel bonding at

MAC layer. In contrast, DVB-C2 is capable of combining various adjacent channels to a single wide-band channel at physical layer. For combining 4 channels, the 4K-IFFT unit of the OFDM generator at the transmitting end needs to be replaced by a 16K-IFFT algorithm. In case 8 channels are to be combined, a 32K-IFFT units needs to be installed in the headend equipment. It is noted that higher order IFFTs can be utilized for backwards compatible transmissions in 6 MHz channels, for instance, requiring a 4K-IFFT algorithm. The feature to combine channels at physical layer has some advantages compared to the conventional bonding approach at MAC layer. For example, the method allows making use of the frequency bands located at the edges of the individual 6 MHz cable channels traditionally occupied by filter slopes of the DVB-C and DOCSIS signals (see figure 3). This feature further enhances the efficiency of DVB-C2 since, for instance, a combination of 4 cable channels results in an increase of the total bit rate which is higher than this factor 4.

#### Support of 6 MHz receiver bandwidth

Another example of a benefit is the possibility to map individual data slices to dedicated OFDM sub-carriers and thus to dedicated frequency sub-bands of the OFDM spectrum. In addition, DVB-C2 ensures that the L1 signaling has a periodic structure with a repetition period equal to 6 MHz (in the US – 8 MHz in Europe). As the wanted data slice has an equal or smaller bandwidth, it is possible for a receiver devices operating at a bandwidth of 6 MHz to receive a 6 MHz frequency window of the DVB-C2 spectrum although the entire bandwidth of the DVB-C2 signal is 18 MHz, for instance. In fact, the receiver decodes only those sub-carriers transmitted within this 6 MHz window, as illustrated by figure 3.

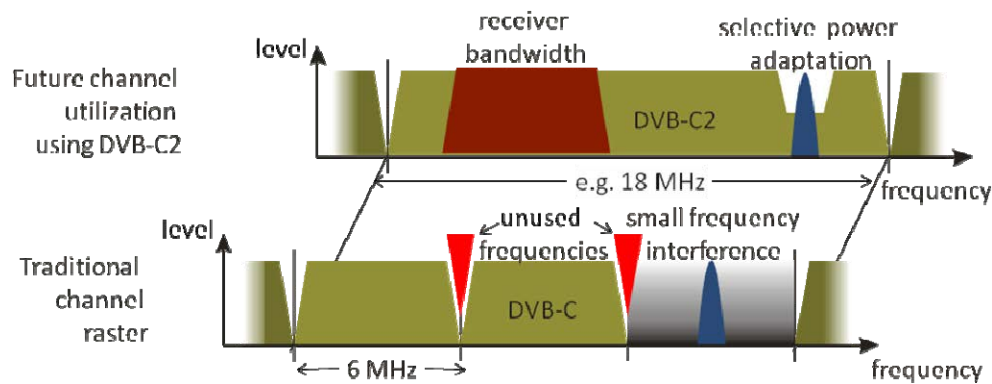

Figure 3: Illustration of features of DVB-C2s OFDM based transmission techniques

### Prevention of narrow-band interference

Figure 3 also shows a further useful feature of DVB-C2. The signal power of subcarriers can be reduced to selectively adapt the power density distribution of the signal for prevention purposes of co-channel interference. This feature can be helpful in case a safety radio service transmitted at a co-channel frequency needs to be protected by regulation. While occupying the remaining part of the channel, DVB-C2 reduces only the power of those subcarriers transmitted at the critical frequencies.

### PERFORMANCE FIGURES

This section provides information about the performance of DVB-C2. In many technical articles, the bit-error rate (BER) as a function of signal-to-noise ratio (SNR) is used to demonstrate the performance of a transmission system. This article chooses the spectral efficiency as an appropriate performance indicator. Digital transmission systems equipped with powerful error correction mechanisms produce BER curves with very steep slopes. In practice this means that we can refer to a

single SNR value above which perfect reception is achieved whereas below that value no reception is possible (see related marks for DVB-C and DVB-C2 in figure 4). The spectral efficiency adds information about the available capacity in terms of bit-rate per Hz bandwidth.

### Simulation parameters

The spectral efficiency figures presented in this article were obtained by means of computer simulations carried out at Institut fuer Nachrichtentechnik at Technische Universitaet Braunschweig for the research project ReDeSign. The results represent a quasi error-free DVB-C2 transmission in a Gaussian noise environment.

For the simulation, 4 channels, each of a bandwidth of 6 MHz, are combined to form a wide-band channel of 24 MHz. A guard interval length of 1/128 of the symbol duration was chosen as well as the corresponding pilot density of 1/96. Each of the 2 spectral guard bands at the wide-band channel edges has a width of 200 kHz.

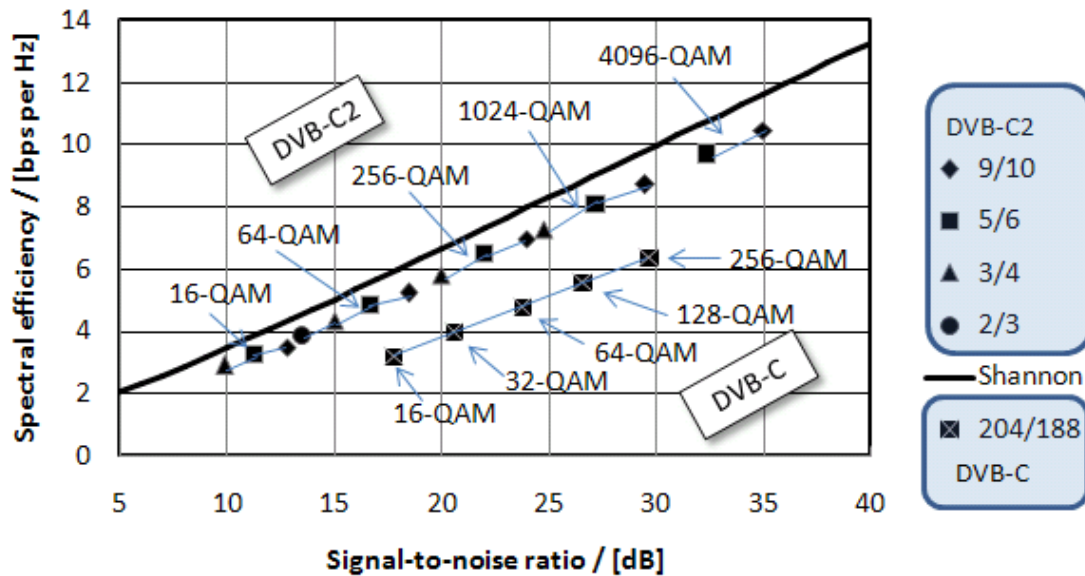

Figure 4: Spectral efficiency as a function of SNR for DVB-C2 and DVB-C

For determining the general performance of DVB-C2, an additive white Gaussian noise (AWGN) channel model was implemented. This rather simple channel model allows a better comparison with equivalent performance figures of DVB-C and DOCSIS which both represent digital cable transmission systems in operation today. In addition, the results can be better compared with the Shannon limit [12], [13] defining the theoretical channel capacity limit for the transmission of digital information through channels impaired by Gaussian noise. A more sophisticated cable channel model was implemented in the further simulations explained later.

#### Increased robustness

The diagram in figure 4 clearly shows the advancement of DVB-C2 compared to DVB-C (and DOCSIS, respectively) in terms of both spectral efficiency and reduction of SNR required for reception of a signal with a dedicated spectral efficiency. In the following, the 64-QAM mode is used by means of an example. This modulation scheme provides a spectral efficiency of almost 4.8 bps per Hz when applied in both DVB-C and

DVB-C2, the latter using a code rate of 5/6. It is observed that the robustness of DVB-C2 increases by some 7 dB compared to DVB-C. The SNR required to receive the corresponding DVB-C signal equals approximately 24 dB whereas the simulation of the equivalent DVB-C2 signal resulted in a required SNR of some 17 dB.

#### Increased spectral efficiency

Comparing the spectral efficiencies of both technologies at an SNR of 24 dB (e.g. 64-QAM for DVB-C and 1k-QAM for DVB-C2), it is observed that the efficiency increases from 4.8 bps per Hz to 7 bps per Hz which is an increase of almost 50 %.

First estimations of efficiency gains based on an introduction of DVB-C2 in combination with further technologies such as statistical multiplexing and advance audiovisual coding (e.g. MPEG-4) resulted in a total efficiency increase of more than 100 %. This figure corresponds with a bandwidths saving achievable in cable networks of more than 50 %.



## FURTHER SIMULATIONS

Further system simulations were carried out using a more sophisticated channel model. The model was developed within ReDeSign. It compiles information generated in earlier research work (e.g. by IEEE 802.14 [7], DigiSMATV [14]) as well as by ReDeSign internal studies and measurement campaigns. Different parameter sets of the channel model were defined to address the varying transmission conditions of real networks as well as to reflect short-term and longer-term network scenarios. For the short-term scenario, a mixed transmission of analogue and digital signals was considered whereas the longer-term scenarios reflected the situation after analogue switch-off.

The complex channel model includes typical impairments which a signal suffers when travelling through a cable network such as phase noise, echoes, impulse noise, etc. While the statistical or deterministic nature and quantity of several impairments is well known to the cable industry, one of the most challenging investigations for completing the channel model was the study of effects created by interference which are generated by non-linear transfer functions of active cable components. In particular, the contribution from digital signals in both a mixed analogue-digital and a digital-only environment was analyzed. Measurement campaigns were organized at premises of equipment manufacturers Kathrein and VECTOR (the latter also being a member of the ReDeSign consortium). At the labs of the two companies, a cable network emulator was set up compiling a chain of broadband amplifiers and an optical link as well as in-home network components. The network emulator was fed with 94 DVB-C signals. Alternatively, a mixed signal scenario with adequate signal numbers was established. Intermodulation products were captured into a large memory for statistical investigations performed afterwards. These investigations

are not completed yet. First preliminary conclusions show that intermodulation products of digital signals have an impulsive noise-like behavior with a varying statistical occurrence probability of their amplitudes depending on the network load and on the signal levels respectively. Related investigations performed mainly by the Dutch research institution TNO (member of the ReDeSign consortium) are ongoing. [5] It is planned to submit the results to CENELEC [14] and IEC [15].

## SUMMARY

Launched by a request from European cable operators, the DVB Project has developed a second generation downstream transmission technique for cable networks called DVB-C2. The specification defines a toolbox providing a set of parameters utilizable to adapt the system to varying transmission conditions of the networks in Europe and worldwide. The spectral efficiency compared to DVB-C and DOCSIS has been increased considerably and allows transporting more than 60 Mbps through a regular cable channel of 6 MHz. Many advantages are supported by means of the flexible channel bandwidth agility of the system. During its development the DVB TM-C2 experts have taken account of the requirement for a low latency mode allowing to incorporate the DVB-C2 physical layer technology in the existing DOCSIS system. DVB-C2 therefore has the potential to become the physical layer and lower layer signalling technology for the future generations of cable based downstream transmission systems.

## ACKNOWLEDGEMENT

The authors appreciate the European Commission's funding and support given to the ReDeSign project. We also thank the member companies of the ReDeSign consortium,



namely Alcatel-Lucent, ANGA, BLANKOM Digital, Telenet, TNO, VECTOR, ZON TV Cabo who all have contributed to the findings presented in this article. Without the important technical contributions to the development of the DVB-C2 specification made by the members of the DVB Technical Module and its experts group TM-C2 represented by its chairman Christoph Schaaf of Kabel Deutschland it would have not been possible to write this article. We thank all of them for the devotion to the DVB-C2 development. In particular we thank the representatives of Sony for the excellent cooperation in creating the DVB-C2 encoder and decoder modules of the software platform. Also the opportunity provided by Kathrein to analyze the effects of intermodulation products generated by digital cable signals at the labs at Kathrein premises is appreciated by the authors. Eventually, the cooperation with CENELEC made possible through a liaison with ReDeSign is greatly acknowledged.

#### REFERENCES

- [1] Reimers, U.: DVB – The Family of international standards for Digital Video Broadcasting, 2<sup>nd</sup> Ed. Springer, Berlin Heidelberg New York, 2005
- [2] Data-Over-Cable Service Interface Specifications – Downstream RF Interface Specification. CableLabs, September 2008
- [3] Digital Video Broadcasting project, DVB, [www.dvb.org](http://www.dvb.org) (status 28.01.2009)
- [4] ReDeSign project, [www.ict-redesign.eu](http://www.ict-redesign.eu) (status 28.01.2008)
- [5] HFC Channel Model. ReDeSign Deliverable 08, December 2008, , [www.ict-redesign.eu](http://www.ict-redesign.eu) (status 28.01.2009)
- [6] Kolze, T.: HFC Channel Model Submission, IEEE Project 802.14, Cable TV Protocol working Group, 26 May 1998
- [7] Advanced Coding and Modulation Schemes for CATV systems (DVB-C2) – Use Cases and Commercial Requirements. DVB internal document no CM-C20018R4, January 2008
- [8] Information technology – Generic coding of moving pictures and associated audio information: Systems. International Standard ISO/IEC 13818-1, December 2002
- [9] Digital Video Broadcasting (DVB); Generic Stream Encapsulation (GSE) Protocol. ETSI TS 102 606 V1.1.1, October 2007
- [10] Lin, S.; Castello, D. J. Jr.: Error Control Coding. 2<sup>nd</sup> Ed. Pearson Prentice Hall, New Jersey, 2004
- [11] MacKay, D. J. C.: Good Error-Correcting Codes Based on Very Sparse Matrices. IEEE Transactions on Information Theory, Vol. 45, No. 2, March 1999
- [12] Shannon, C. E.: A mathematical theory of communication, Bell System Technical Journal, vol. 27, pp. 379-423 and 623-656, July and October, 1948
- [13] Shannon, C. E.: Communication in the Presence of Noise. Proceedings of the IEEE, VOL. 86, NO. 2, February 1998 (reprint)
- [14] [http://www.cenelec.eu/Cenelec/European Committee for Electrotechnical Standardization, CENELEC,](http://www.cenelec.eu/Cenelec/EuropeanCommitteeforElectrotechnicalStandardization,CENELEC,) [www.cenelec.eu](http://www.cenelec.eu) (status 28.01.2009)
- [15] International Electrotechnical Commission, IEC, [www.iec.ch](http://www.iec.ch) (status 28.01.2009)