

CUSTOMER PREMISES EQUIPMENT PERFORMANCE AND COMPATIBILITY

Claude Baggett
Cable Television Laboratories, Inc.
Boulder, Colorado

Abstract

In part 17 of the Cable Act of 1992, the congress made provisions for the specification of those features of television sets, VCRs, and cable converters which would determine whether they could truly be considered "cableready" or not. The primary performance shortfall experienced by most consumer hardware which made them unsuitable as a cableready unit involved their susceptibility to direct pickup interference (DPU). However, in addition to DPU, there were a number of other tuner performance factors which were important in this definition. CableLabs performed certain work to size the DPU problem, to measure the actual performance of a number of types of consumer premises equipment related thereto, and to determine a threshold level for the perceptibility of such interference. In addition, CableLabs devised test procedures for measuring both DPU and the other tuner performance factors, and tested an additional number of consumer and cable units to develop a state of the industry in these performance areas. This report subsums these efforts and their results.

1.0 GENERAL SUMMARY

1.1 Background

To facilitate the viewing of any television programming over a cable system, a long, multi-industrial chain of processes must take place in a fortuitous manner. A television segment begins with the creative talent and proceeds through the production, distribution, financial, and legal engines, subsequently to be delivered to the over 10,000 cable television headends in the United States. These various operational elements perform their efforts in relative harmony with well-defined and cooperative interfaces, considering the complexity of the system. But once the signals pass through the cable headend and are transported to the customer home over the cable system, there is yet one additional interface which must be bridged, that being between the cable delivery

system and the consumer electronics display devices which are the last parts of the electronic system before the visual and aural signals are available to the human receptor, the object of the whole system. This interface has been problematic since the very early days of cable, about 50 years ago, is still so today, and provides the rationale for the research and measurements documented herein.

There has been considerable effort over the last decade to find a solution to the disharmony at the consumer interface through joint negotiations between the consumer electronics and cable industries. While some progress has been made, there are still many issues yet to be resolved. In fact, Section 17 of the Cable Television Consumer Protection and Competition Act of 1992 ("Cable Act of '92") specifically addresses many of these unresolved problems.

The efforts described in this document are a direct result of these long-standing interface problems and the guidance given in the Cable Act of '92 as to their solution. The EIA/NCTA Joint Engineering Committee ("JEC") has within its purview, responsibility for specifying the performance characteristics of a tuner which would be able to receive cable signals without the degrading side-effects exhibited by the broadcast-oriented tuners found in all consumer products today. In this committee, the absence of two primary data items has blocked real agreement between the main parties, that being the sizing of the problem as to the consumer population impacted by direct pickup interference (DPU), for instance, and the development of a necessary and sufficient specification for the performance of the tuners themselves. Related to both items is the development of acceptable baseline test procedures for each of the factors considered.

Recognizing the difficulty of developing the above extensive materials by such volunteer committees as the JEC, Cable Television Laboratories, Inc. ("CableLabs"), as directed by its member companies and in cooperation with the NCTA and

the EIA, moved to fund the necessary projects to develop the data required to free the JEC to act.

In January, 1992, CableLabs asked Stern Telecommunications Corporation ("STC") of New York City, NY to undertake a study to answer the first question, that relating to the extent and degree to which television receivers in the United States are subjected to various levels of co-channel interference in the cable delivered picture through the mechanism of direct pickup interference. STC was selected because of its interest in and understanding of the problem, and its long-standing and even-handed relations with the broadcast, cable, and consumer industries. As a check of the STC results, the EIA hired Jules Cohen, a respected consultant in the Washington DC area, to perform a similar analysis. The Cohen results were virtually identical to the STC answers, except as to the percentage of CPE which resides in 1 volt/meter fields or greater. The STC analysis indicates about 6% of CPE reside in such field intensities, whereas the Cohen study shows just less than 2%. Even in this, however, there is no significant difference.

In December, 1992, CableLabs issued open solicitations addressing two of the other issues. The first solicitation called for the development of baseline test procedures for determining the susceptibility of customer premises equipment, including television receivers, videocassette recorders, and cable converter units, to the effects of radiated and conducted direct pickup interference, and the testing of a sample of such CPE to determine the general state-of-art. The second solicitation covered the same tasks, but as related to the deteriorating effects of other receiver performance characteristics, such as the re-radiation of cable signals, local oscillator leakage and backfeed, A/B switch isolation, DPU backfeed, VCR through-loss, adjacent channel rejection, image rejection, and tuner overload performance. After evaluation, both contracts were awarded to the Carl T. Jones Corporation ("CTJ") of Springfield, VA. Further discussion re the irradiated and conducted DPU, and the other listed performance factors can be found in sections 1.3 and 1.4 of this Report.

Finally, in August, 1993, CableLabs asked Dr. Bronwyn L. Jones, a much respected researcher relative to the psychophysical effects on the viewer of perceptible degradation in the television pic-

ture, to relate the objective measurements of DPU susceptibility made at CTJ to the actual impact as to perceptibility in the television viewer.

1.2 Statistical Model

While there was a great deal of anecdotal data regarding the cost of cable's response to DPU complaints by subscribers, mainly based on service calls where DPU was the cause, and/or the number of non-descrambling converters deployed specifically to address this problem, there was no definitive data set which allowed the consumer manufacturers to analytically assess the magnitude of the impact of this problem. Frequently requested by the consumer caucus of the JEC was a chart which would apportion television households in the United States as a function of the field strength of the UHF and VHF off-air signals in which they resided. This data is required, so that when combined with that developed in the other efforts contained herein, the DPU problem could be properly sized and an appropriate response planned. This is the thrust of the modeling and verification accomplished by Stern Telecommunications Corp. ("STC") under contract to CableLabs.

The procedure used by STC was to combine literature searches, computer modeling, laboratory measurements, and some specific field verifications to develop the data represented in the summary histogram in figure 1.2.1 below.

The geographic areas evaluated in this study consisted of the top ten television ADIs, which represents approximately 30% of total US households. The varied demographics and physical attributes of these ten ADIs permitted the data to be extrapolated to represent all urban and suburban television homes in the US.

Iso-contours representing varying VHF and UHF field strengths were calculated by the model and the numbers of television homes within each level were developed. Other factors, such as the shielding effectiveness of the CPE, the location within the dwelling, the orientation of the unit to the interfering transmitter, the effects of building shielding, and urban-suburban clutter are part of the CTJ study and not contained in this effort.

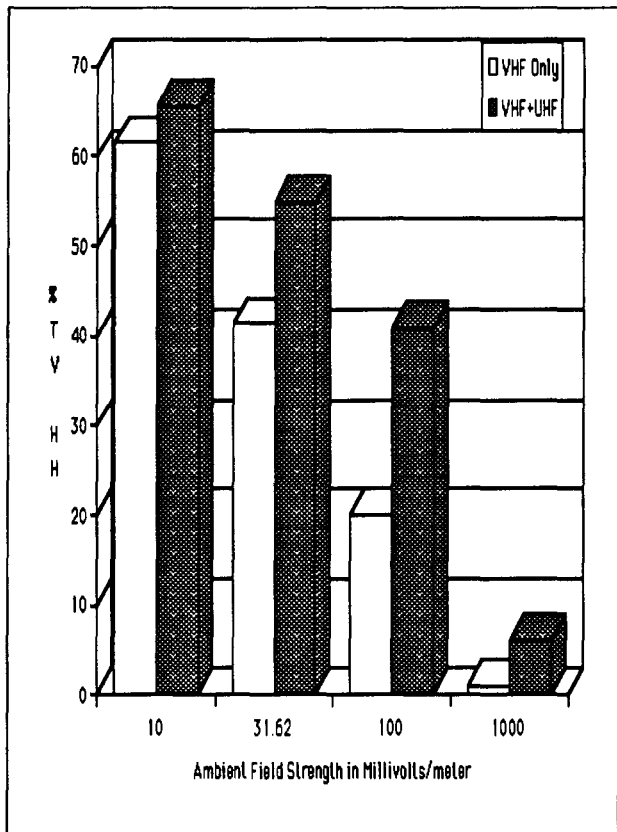

Figure 1.2.1 Allocation of TV households in the STC study as a function of the ambient field strength in which they reside (all US TV HH).

To sum up this chart, it represents that some 65.4% of all US TV households reside in fields of 10 mv/m or greater, that 54.8% of all US TV households reside in fields of 31.62 mv/m (90 dBu) or greater, that 40.8% of all US TV households reside in fields of 100 mv/m or greater, and that 6% of all US TV households reside in fields of 1 volt/meter or greater.

1.3 Direct Pickup Interference Determination

Direct pickup interference, or DPU, exists when external co-channel signals ingress into the tuner in CPE and interfere with and degrade the signal delivered by cable. This ingress may be in the form of an electromagnetic field irradiating the CPE, or in the form of signal currents entering the unit on the power cord or the braid of the coaxial cable connected to the CPE. A need was felt to determine the current state-of-art of consumer grade television receivers, videocassette recorders, and converters relative to their susceptibility to direct pickup interference. It was noted in this testing that the tuners in consumer electronics hardware seemed to be sensitive to the differential

voltage between the braid and the center conductor on the drop cable. This would be consistent with a tuner designed specifically for broadcast signal reception. The tuners in the cable converters typically have a single-ended input from the center conductor of the coax. The results of testing performed which is listed below consider both irradiated and conducted signals.

Technically, any kind of signal not delivered on the cable which is of the proper frequency and amplitude could interfere with and degrade the video. There are two general types of interfering signals, coherent and non-coherent. Coherent signals are those which originate from the same original source, such as a television transmitter. Non-coherent signals are those which come from other sources, such as business radio transmitters, and leakage from other household appliances. The chart in figure 1.2.1 depicts the field strength levels ambient to typical households in the US resulting only from VHF and UHF broadcast television transmitters, thus being coherent signals.

The CableLab's effort at Carl T. Jones Corporation, a nationally recognized and honored testing laboratory which has been conducting programs such as this since 1936, existed in part to measure the susceptibility of television receivers, videocassette recorders, and cable converter boxes to both irradiated and conducted DPU. The units tested included the numbers shown in figure 1.3.1 as received from a sampling of manufacturers ranging from the highest to the lowest in marketshare.

Television Receivers	37
Videocassette Recorders	11
Cable Converters	14

Figure 1.3.1 Sample universe of CPE tested.

In CableLab's arrangements with the EIA regarding the DPU test program, it was agreed that we would not make public the performance of any particular brand or model tested. Rather, the testing results from DPU, as are shown in figure 1.3.2 below indicate only the best performing unit tested, the poorest performing unit tested, and the median, or that set, if it existed, where half the units performed better and half worse.

The criteria used in the CTJ tests recognizes the generally accepted point of perceptibility for interference from coherent signals; notably when the interfering signal reaches an amplitude 55 dB below the sync tip of the desired video signal. This point is further discussed below. Thus, the results shown in figures 1.3.2 and 1.3.3 below represent that point when an interfering signal will be just perceptible to the average viewer observing a television receiver or as displayed from a VCR with that level of interference, or as processed by a cable converter with that level of interference.

Further, the numbers below, as with the STC chart above, do not take into consideration any mitigating factors, such as placement in the home, the degree of building attenuation applicable, urban/suburban clutter, unusual height above ground, ducting possibilities, the orientation of the set relative to the transmitter of the interfering signal, or the type of programming being displayed. These factors will be discussed in our summary conclusions which are found in section 1.6 below and relate to the performance specifications of CPE as described in part 17 of the Cable Act of '92, and in IS-23, which is being developed in the JEC.

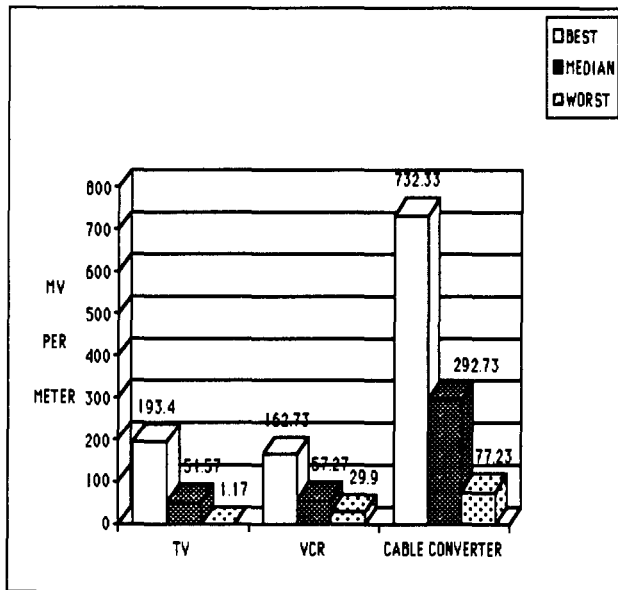

Figure 1.3.2 Ambient field strength in millivolts/meter to achieve the -55dB point of perceptibility averaged over channels 6, 12, and 78.

There are several interesting points which are contained in this histogram. First it must be noted that all CPE exhibit a considerable spread between the best and worst units, television sets being about 165 times, VCRs about 5.4 times, and cable converters being about 9.5 times. This

spread must be considered when setting minimum specifications for DPU performance in CPE. Secondly, since it appears that cable converters perform well enough on average to cure the DPU problem, then improving the TV and VCR performance numbers to match those of the converters would be adequate, but only if the performance span is considered in setting the acceptable range. One of the differences here is that cable technicians often work with several converters until one is found whose performance is equal to the problem, a capability not really available or practical for the consumer electronics customer trying to purchase a new TV or VCR. The conclusion that might be reached is that TVs and VCRs need to improve their worst case performance to a level comparable with the media converter.

In Figures 1.3.3 and 1.3.4 below, the performance of the CPE in the presence of conducted signals on both the coaxial signal cable and the power cord were measured. These tests were performed utilizing signals on channels 6 and 12, and measured at the -55 dB point of perceptibility. Among the test items there did not seem to be a consistent susceptibility to a particular mode of conducted DPU.

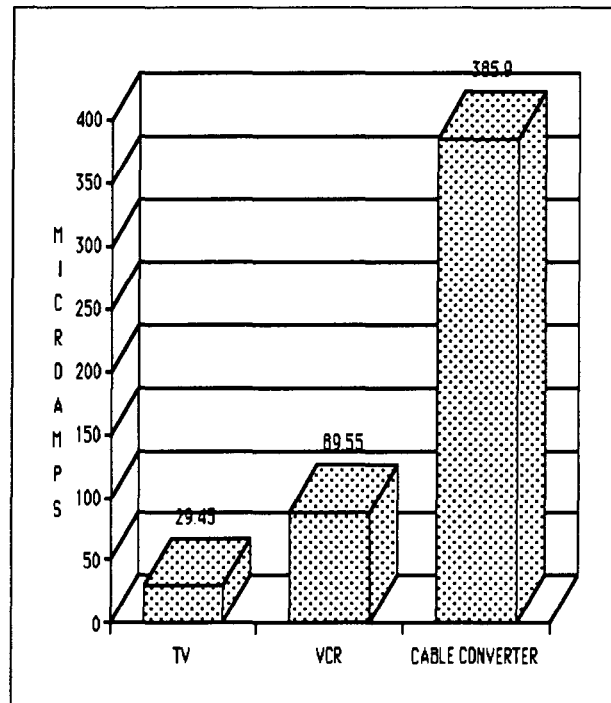

Figure 1.3.3 Susceptibility of CPE to conducted coherent direct pickup interference through current on the coaxial cable braid at the -55dB level of perceptibility, channels 6 and 12 averaged.

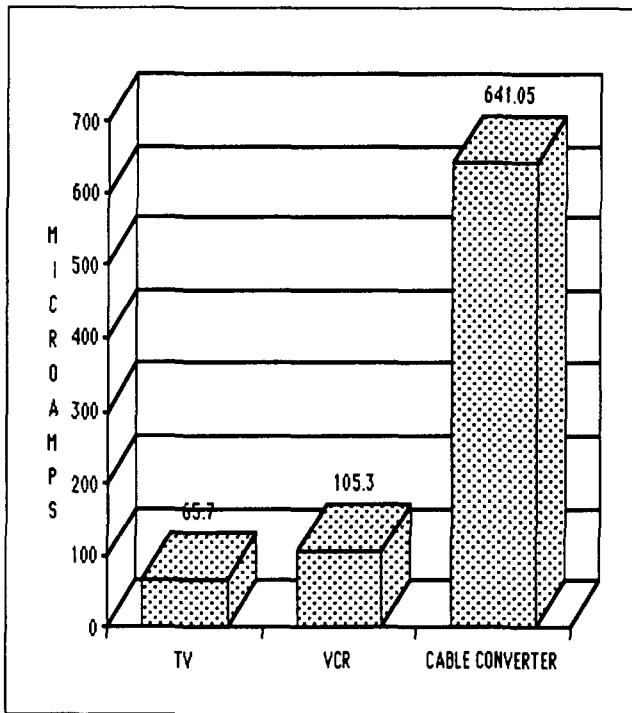

Figure 1.3.4 Susceptibility of CPE to conducted coherent DPU on the power cord at the -55dB level of perceptibility, channels 6 and 12 averaged.

In considering this data, one must remember that it is generally accepted that all consumer electronics hardware sold today have excellent broadcast or off-air tuners, whereas the cable converter has a tuner which is designed and oriented toward cable delivery and not toward the reception of off-air signals. The broadcast tuner is designed to be exceptionally sensitive to signals derived from all sources including those which are conducted, thus making it a perfect conduit for DPU when the unit is connected to a cable television delivery system. Therefore, if a piece of consumer gear is intended, labeled, promoted, and sold to be used only with broadcast signals, or only with a cable converter placed before it in the signal stream, the current tuners in the television receivers are sufficient.

However, if the consumer gear is intended to be usable with cable systems either without a cable converter or with a decoder interface, then an accommodation must be made when connected to such systems to remove the interfering DPU signals regardless of their source of ingress, whether through irradiated or conducted modes, to a level which will not be perceptible to the customer.

1.4 Receiver Performance

In the past, the FCC has been reticent to impose any performance standards on consumer grade hardware, preferring to leave that as a marketplace issue. Since cable has become the marketshare leader in the delivery of video in the United States, certain factors at the retail point-of-sale has caused the consumer to become confused as to the expected performance of the intended purchase. In all but a very small percentage of high-end consumer electronics stores, the television receivers are all displayed with the exact same material delivered primarily from a nearby laserdisk player or other such source, and/or broadcast signals. In this most common case, the consumer cannot ascertain the consumer electronics' compatibility with cable (which is much different than the other sources), at the time of purchase, because the stores do not generally provide access to the local cable system. Therefore, the selection of consumer hardware based on their compatibility with cable delivery systems is not currently resolvable at the point of sale. For this reason, there are several other tuner performance issues which need to be specified to avoid confusing and misleading the consumer.

In devising the following tests procedures, eight parameters of CPE performance were considered. These parameters are taken from those listed in the IS-23 performance document which is currently being crafted in the EIA/NCTA Joint Engineering Committee (JEC) through a bi-industry subcommittee. These test procedures were selected after consideration by CTJ of existing practices for performing such tests among consumer and cable manufacturers both domestic and foreign, and as discussed in extensive technical documents. Considerable time was spent in proving the test procedures by varying the facility elements and finally in retesting many of the same products used in the DPU considerations as a sort of "test of the test." While the procedures must be represented as unapproved as yet by the consumer caucus of the JEC, the exhaustive certifications performed at CTJ has convinced CableLabs and the cable caucus that any substantive and supported changes suggested will vary the results in only a very minor fashion, and not the scale or proportion of the results in any way.

The goal of this work at CTJ was two fold. First, it was anticipated that the test procedures developed for each of these performance param-

eters will be canonized, or modified and canonized, or equivalent alternatives procedures suggested, these becoming the benchmark techniques for measuring each of the eight parameters. Secondly, it was anticipated that the actual performance numbers developed will give a good measure of the state-of-art currently existing among the consumer electronics and cable equipment manufacturers relative to these factors. Note that the work at CTJ was not designed and is not meant to show preference to any particular consumer product, or between the consumer manufacturing or cable industry view of the interface, but rather to build a foundation of commonly accepted procedures, technology, and information from which meaningful remedies for problems at the interface can be developed.

1.4.1 Re-radiation of Cable Signals

The cable industry is required under the Cumulative Leakage Index (CLI) performance standard set by the FCC in Part 76.605 (a)(12) of their Rules and Regulations to limit the leakage or the egress of RF energy out of the delivery system back into the environment. As cable has complied with this directive, concern has been expressed as to determining what contribution, if any, CPE might make toward the CLI through the leakage and reradiation of cable signals. Note that this does not imply that CPE is currently required to meet the Part 76 standards. Nonetheless, this federal standard limits the radiation from a cable delivery system to 15 microvolts/meter at a distance of 30 meters for frequencies less than or equal to 54 MHz or greater than 216 MHz. Similarly, limits are placed at 20 microvolts/meter at 3 meters between 54 and 216 MHz. The test measurement system, shown in Figure 1.4.1.1 below, was designed and calibrated to have sufficient sensitivity to measure signals in light of the FCC requirements.

Only two of the 56 CPE tested, both television receivers, presented any re-radiation of cable signals above the FCC limits. All units tended to re-radiate higher levels of signals as frequency increased, but all were well within limits except these two units, both of which would have failed the Part 76.605 (a)(12) cable CLI emission limits on channels 37 and 53, if it were to be applied against CPE.

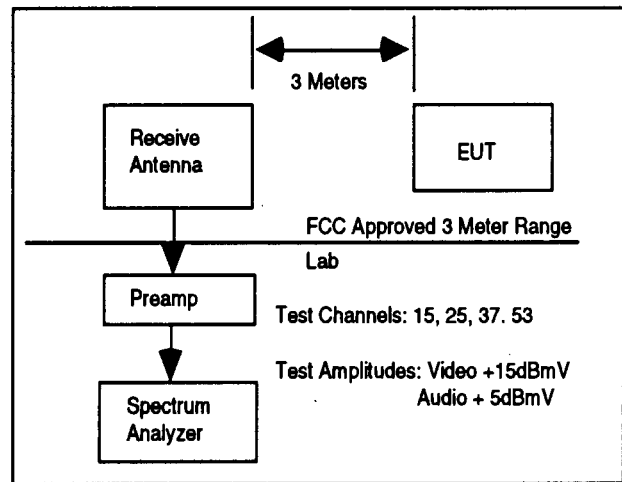

Figure 1.4.1.1 Test Configuration for Re-Radiation of Cable Signals.

1.4.2 Local Oscillator Leakage and Backfeed

In the single conversion tuners found in most consumer electronics, there is a single local oscillator (LO) whose signal is used to heterodyne the incoming RF television transmission down to an intermediate frequency which is in the 40 MHz region. In converters built for the cable industry, a double conversion process is utilized, requiring two such oscillators, each being isolated from the other and from the balance of the circuitry. In the single conversion tuners in most consumer gear, the local oscillator frequency falls within the cable delivery band, while the frequencies used in the cable converters typically fall outside the band. It is recognized that in the future, consumer manufacturers may exercise some changes to the frequency of these signals, and this will require further investigation. The test configuration is shown in Figure 1.4.2.1, below.

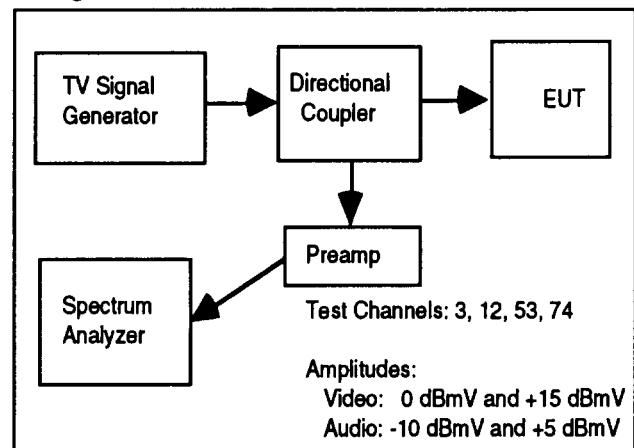

Figure 1.4.2.1 Test Configuration for Local Oscillator Leakage and Backfeed.

In the in-band case, if the emanations from these oscillators are conducted out of the tuner package on the interconnecting wiring, they serve as a source of degradation to other CPE devices connected nearby, and if sufficiently strong, to traverse the cable drop and ingress into the cable system as noise, or through the cable tap to the drop of a neighboring subscriber as interference. The degree to which these local oscillators are isolated to within the tuner package is a performance factor of interest at the interface, and is part of the IS-23 deliberations. In this test, any spurious emissions which exceed -35 dBmV within the spectrum up to 600 MHz were recorded. The worst case situation is where the LO in the TV being generated while viewing one channel degrades the reception of another channel being recorded on the co-located VCR, or vice-versa.

This phenomena, like many others in these investigations, seems to be directly proportional to the frequency of the channel tuned. Television receivers showed no emanations above the recommended level on channel 3, but numerous instances of problem levels on channels 12, 53, and 74. Specifically, 17% of the test items had problems on channel 12, 31% on channel 53, and 60% on channel 74.

Videocassette recorders were quite similar, showing 13% having problems on channels 3 and 12, 26% on channel 53, and 50% on channel 74.

Cable converters showed no emissions above the recommended level on any channel, but did follow the precedence set by the other CPE in scoring somewhat worse on the higher frequencies.

1.4.3 A/B Switch Isolation

All VCRs, some TVs, and some cable converters are equipped with an A/B switch to provide for the selection of more than one input source to the CPE for use. In the case of the VCR, the choice is between the tape playback unit in the VCR or passing the incoming cable signal on to the television receiver.

If insufficient isolation exists between the two external ports, or between any unselected external port and the common port, then a condition of signal crossfeed will exist, which may result in degradation to the viewed or recorded signal. The FCC requires in Part 15.606 of their

Rules and Regulations that A/B switches present a minimum of 80 dB of isolation for frequencies between 54 and 216 MHz, and 60 dB from 216 to 550 MHz. The external mechanical A/B switches currently in use by the cable industry all generally exceed 90 dB of isolation under any of the above operating modes at any frequency, and often exceed 100 dB at any frequency.

It was deemed important to know what the state-of-art is for A/B switches among currently manufactured CPE. This did not seem to be a great problem among the television sets tested, having only 3 instances where the results did not meet Part 15.606 on the 4 channels tested. In fact, 75% of the receivers had no problem on any frequency. The test configuration is shown in Figure 1.4.3.1 below.

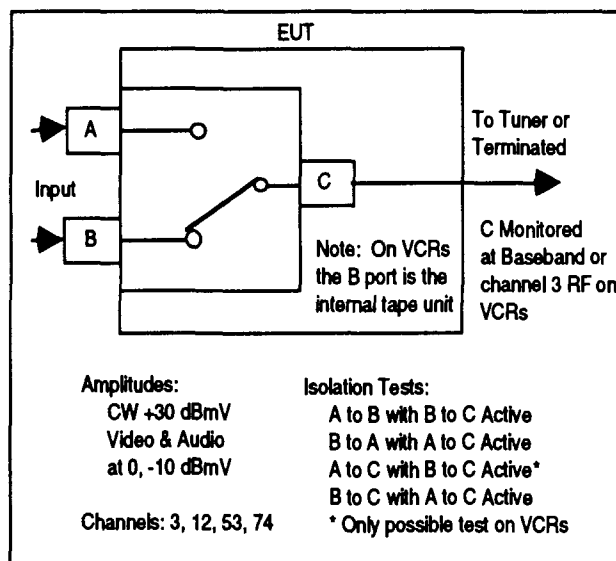

Figure 1.4.3.1 A/B Switch Isolation Test Configuration.

1.4.4 DPU Backfeed

This represents the condition wherein CPE which is susceptible to DPU not only causes its own picture to be degraded, as explained in Section 1.3 above, but also allows these ingressive signals to be fed back up the coaxial cable, thus serving as a degrading factor to other hardware in the home, or customers on the cable plant. The values measured represent the voltage present at the input port of the CPE while it is being irradiated with a 100 millivolt/meter field at the unit's point of maximum susceptibility, as explained in the DPU section. Tests showed that the DPU backfeed is a function of the impinging radiation, and not related to the channel tuned on the EUT. The FCC

requires a minimum of 18 dB of isolation between customers, but standard practice shows a practical isolation figure to be about 22 dB. If the -55 dB D/U ratio is the point of perceptibility, then a -33 dB level out of the RF input of the EUT is sufficient to reach the threshold of perceptibility. The test configuration is shown in Figure 1.4.4.1 below.

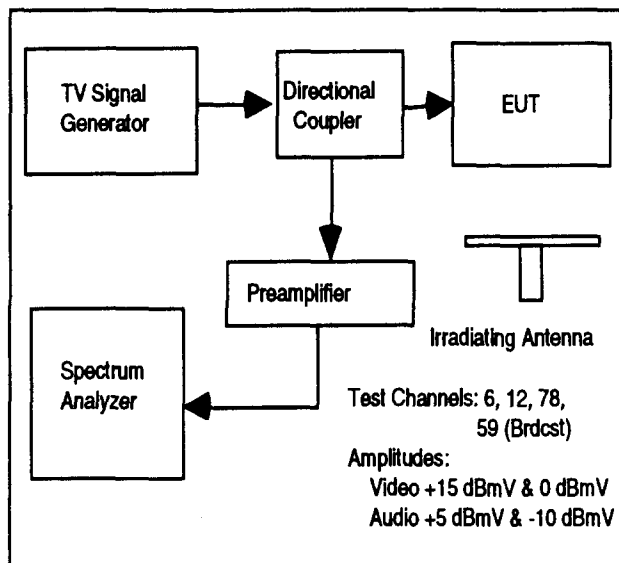

Figure 1.4.4.1 Test Configuration for DPU Backfeed.

The results show that 37% of television receivers had DPU backfeed above the point of perceptibility on channel 6, followed by 34% on channel 12, 26% on channel 78, and 17% on channel 59. In general, there was a high correlation between those television receivers which tested poorly on DPU, and those which did poorly in DPU backfeed. Interestingly, no videocassette recorders or cable converters displayed DPU backfeed above the level of perceptibility.

Further tests of spurious backfeed were conducted to look for any emission from the EUT present at the cable fitting in the 54 MHz to 550 MHz range which might cause interference in connected CPE. Any signals greater than a -35 dBmV were recorded. The emissions found in television receivers all seemed to be related to the 40 MHz IF frequency, but in no case were they above the -35 dBmV level. No such emanations were found in videocassette recorders. All converters except one, a commercial aftermarket tuner-only product, showed no significant emanations. The failed converter showed a very strong -1.7 dBmV backfeed at 144 MHz when tuned to channel 12, and -2.8 dBmV backfeed at 336 MHz when tuned to channel 53. It was below the test facility

sensitivity on the two other channels.

1.4.5 VCR Through-Loss

The usual and accepted configuration for introducing cable to an arrangement in the home having both a TV and VCR is to route the cable drop to the cable converter, thence out of the converter to the VCR, and thence to the television receiver. In cable systems where a converter is not required, the usual practice is for the drop to be connected to the VCR input port, with the signal path thence traveling to the TV. If there is excessive signal loss in passing through the VCR, a noisy picture may be presented to the viewer. This probably is not an issue at the FCC prescribed input levels if the division of the input signal energy available on the cable is performed in a symmetrical fashion, with half going to the VCR and half to the balance of the system. However, it has been noted that some VCRs perform asymmetrical splitting of the signal, diverting a disproportionate amount of the signal energy internally to the recording unit, thus obviating the cost of some amplification within the VCR. The test configuration is shown in Figure 1.4.5.1 below.

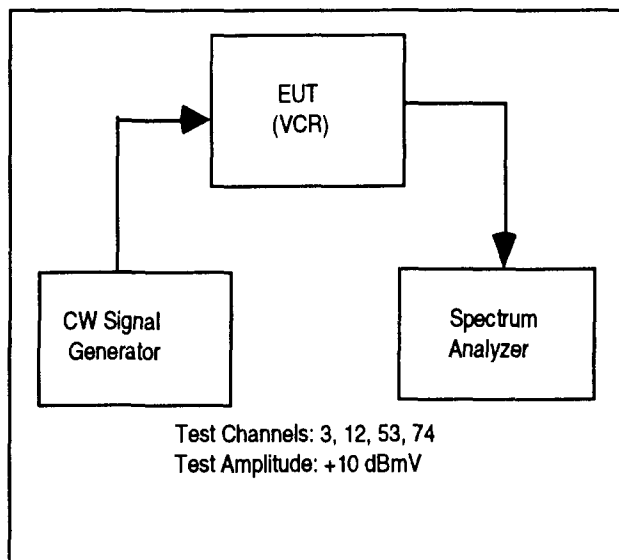

Figure 1.4.5.1 VCR Through-Loss Test Configuration.

It was decided to perform a VCR through-loss measurement on our sample set to determine the state of art in the industry today. Of the eight VCRs tested, all were contained in the range of 3.4 to 5.0 dB through-loss, as tested over channels 3, 12, 53, and 74. The average through-loss for the eight samples over the four channels was 4.05 dB.

1.4.6 Adjacent Channel Rejection

The ability of CPE to reject the in-band noise contribution from channels adjacent to the tuned or desired channel is an important factor in the performance of receivers. It is primarily the lower adjacent aural and color subcarriers, and the upper adjacent video carrier which create the problem. This issue has been addressed in the broadcast industry by leaving adjacent channels vacant, where possible. However, in the cable industry, where virtually all channels have upper and lower adjacents, and at relatively high levels, as specified by the FCC, adjacent channel interference becomes a very important performance factor having great impact on picture quality. The test configuration is shown in Figure 1.4.6.1 below.

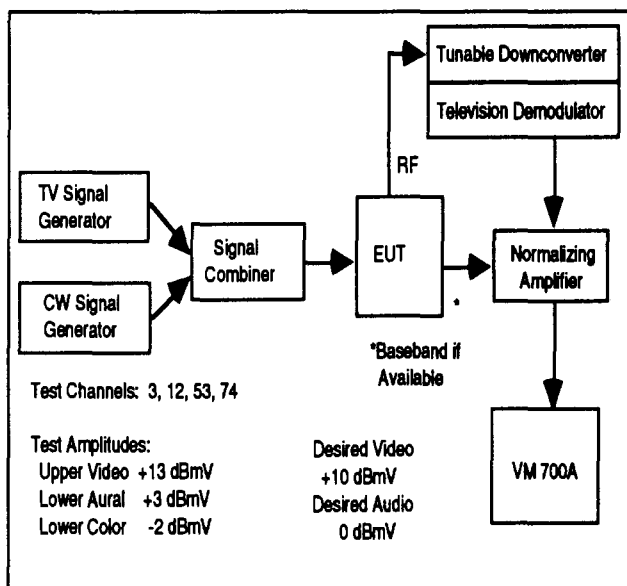

Figure 1.4.6.1 Test Configuration for Adjacent Channel Rejection.

The measurements, were divided into three parts, that for the lower adjacent color subcarrier, that for the lower adjacent aural carrier, and that for the upper adjacent channel video carrier. Again, the -55 dB D/U ratio was used as the threshold of perceptibility for degradation in the viewed picture. The desired video carrier was set at +10 dBmV. The upper adjacent video carrier was set at +10 dBmV, the lower adjacent color subcarrier at -2 dBmV, and the lower adjacent aural carrier at 0 dBmV.

Television Receivers - Lower Adjacent Color Carrier Rejection. Three of the 35 television

receivers showed a failure in lower adjacent color subcarrier rejection, all on a single channel only, one unit on channel 12, the other two on channel 53. All of the other numbers for the television receivers were quite respectable, resulting in averages for all receivers at least 10 dB in margin better than the point of perceptibility.

Videocassette Recorders - Lower Adjacent Color Carrier Rejection. One VCR failed the lower adjacent color subcarrier rejection test on all channels, averaging a -49.9 dB D/U level. Two of the eight test units failed on channel 74 by very small margins. All other numbers were acceptable, and the averages for all test items were at least 5 dB better than the level of perceptibility.

Cable Converters - Lower Adjacent Color Carrier Rejection. No cable converter exhibited insufficient rejection of the lower adjacent color subcarrier to the point of perceptibility on any channel.

Television Receivers - Lower Adjacent Aural Carrier Rejection. Two of the 35 units had insufficient lower aural rejection on all channels while two other sets were perceptible only on channels 53, and 74. The average D/U for all 35 receivers tested on all channels was at least 9 dB better than the level of perceptibility.

Videocassette Recorders - Lower Adjacent Aural Carrier Rejection. Three of the eight VCRs tested showed no perceptible interference on any of the four channels tested. Three of the test items failed on all four channels. One VCR failed on channels 12, 53, and 74, while the final unit failed only on channel 74. However, there was little or no margin in the averages over the four channels above the point of perceptibility, the highest being only 1.8 dB above the 55 dB ratio.

Cable Converters - Lower Adjacent Aural Carrier Rejection. None of the cable converters exhibited insufficient rejection of the lower adjacent aural carrier.

Television Receivers - Upper Adjacent Video Carrier Rejection. No television receivers exhibited insufficient rejection of the upper adjacent video carrier.

Videocassette Recorders - Upper Adjacent Video Carrier Rejection. No VCRs exhibited insufficient rejection of the upper adjacent video

carrier.

Cable Converters - Upper Adjacent Video Carrier Rejection. No converters exhibited insufficient rejection of the upper adjacent video carrier.

1.4.7 Image Rejection

The effects of insufficient image rejection is a noise contribution to the desired channel similar in nature to adjacent channel interference. However, it is the signals occupying the upper portion of the channel which is 14 channels above the desired, and the lower portion of the channel which is 15 channels above the desired channel which contribute the noise energy.

For NTSC, it is the aural carrier 14 channels above, and the visual channel 15 channels above which combine with the desired signal to generate the distortions. The FCC requires on cable that visual carriers measured at the CPE vary no more than 10 dB, plus 1 dB for each 100 MHz of bandwidth above 300 MHz. Therefore, in our test 550 MHz spectrum, there can be a variation as high as 13 dB. In the tests, the desired video carrier was set at 0 dBmV and the image carrier at +13 dBmV, according to the above. The test configuration is shown in Figure 1.4.7.1 below.

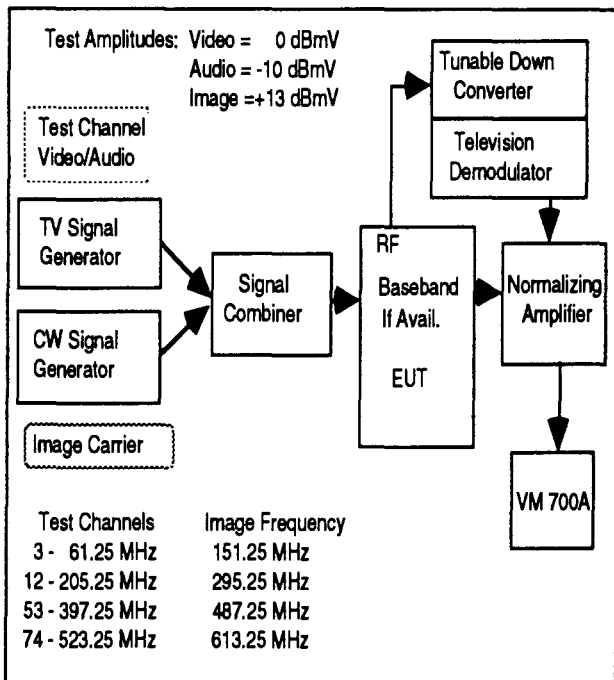

Figure 1.4.7.1 Test Configuration for Image Rejection

A review of the results shows that the image rejection performance of television receivers varies significantly according to the selected channel. On channels 3 and 12, the average rejection was found to be 66 dB, while on channels 53 and 74, the average image rejection was 58.5 dB. None of the television sets exhibited perceptible or greater interference on channel 3, and only four were above the threshold on channel 12. However, 50% of the receivers had perceptible interference on channel 53 and 67% were above threshold on channel 74.

1.4.8 Tuner Overload Distortions

Tuner overload performance has become increasingly important for CPE connected to cable as the number of channels carried thereon has continued to increase. The inability of the tuner to accept the aggregation of these high-level signals without generating excessive distortion products through the non-linear characteristics of the receiver's RF input circuitry results in the issue. The two most destructive products generated in this process are referred to as Composite Triple Beat (CTB) and Composite Second Order (CSO). The CTB product falls on the video carrier of the desired channel, and the CSO is either at ± 0.75 MHz or ± 1.25 MHz from that carrier, according to the channelization plan of the system, standard or IRC. The test configuration for Tuner Overload measurements is shown in Figure 1.4.8.1 below.

A total of 66% of the television receivers tested exhibited degradation above the "just perceptible" level on at least one channel and in at least one category. The television receivers showed perceptible degradation on all four of the channels tested.

A total of 50% of the VCRs tested showed perceptible degradation on at least one channel and in at least one category. However, the degradation was perceptible only on channels 53 and 74, and not on channels 3 and 12.

A total of 36% of cable converters showed perceptible degradation on at least one channel and in at least one category, with the visible degradation present on each of the four channels.

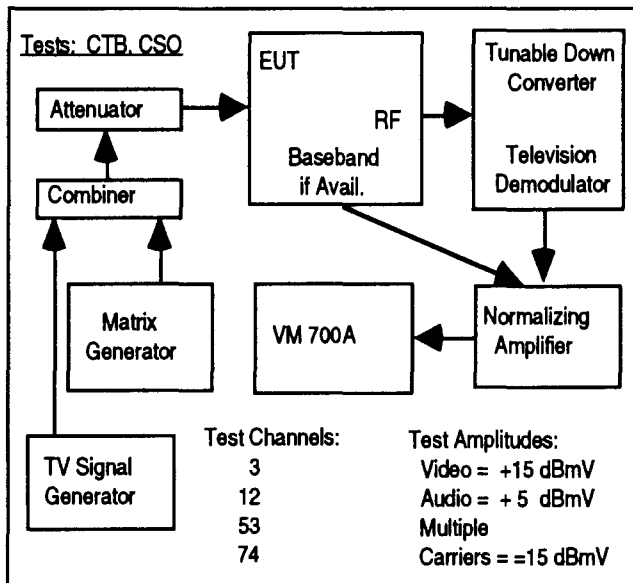

Figure 1.4.8.1 Test Configuration for Tuner Overload.

1.5 Viewer Perceptibility and the Selection of the -55dB Benchmark

There is always a great paradox in testing factors related to viewing television. One would like to devise objective techniques for testing receiver performance, since subjective tests often lack repeatability and precision. Subjective tests which are designed to have precision and reliability, often require such extensive procedures as to make them impracticable for widespread use. On the other hand, it is the subjective viewing of the television receiver, regardless of its signal source, which determines the acceptability of the delivered video to the viewer. Extensive testing has been accomplished in times past, attempting to bridge the gap, to enjoy the advantages of objective testing, while yet relating the results to some measure of subjectivity, such as the threshold of viewer perceptibility or the threshold of viewer annoyance.

These past studies have always been indexed to some particular form of interference, such as NTSC co-channel signals interfering with NTSC signals, or NTSC signals being degraded by non-coherent, non-video signals, such as in-band business radio emissions. Then, based on the type of interference, some measure could be made which would state that statistically the threshold of perceptibility occurs when the interfering signal is N dB, below the sync tip of the desired video signal.

The point of Dr. Bronwen Jones' effort was to perform a series of subjective perceptibility tests using exactly the same facility CTJ had used for performing their objective DPU measurements. We had assumed at the outset of the project that the -55dB desired to undesired ratio (D/U) was appropriate for the configuration used at CTJ to test for DPU susceptibility. In fact, the DPU measurements are linear, so the results contained herein can be adjusted based on the consensus ratio without redoing the tests.

The result Dr. Jones developed in her research shows, however, that the -55 dB point is indeed the threshold of perceptibility among the viewing panels assembled and supports the supposition made in establishing the DPU test procedures at CTJ. Please refer to Section 5. below for a full treatment of the findings.

1.6 Conclusions and Recommendations

In this section an attempt will be made to summarize the results of the above testing in a narrative format, drawing such conclusions as are supported by the data.

We have learned from the Stern study:

- That 65.4% of all US TV households reside in fields of 10 millivolts/meter (mv/m) or greater,
- That 54.8% of all US TV households reside in fields of 31.62 mv/m (90 dBu) or greater,
- That 40.8% of all US TV households reside in fields of 100 mv/m or greater,
- That 6% of all US TV households reside in fields of 1 volt/meter or greater.

In each of the 60 million cable homes there are an average of 2.3 television receivers, 1.8 videocassette recorders, and 0.33 cable converters. This yields about 138 million TVs, 108 million VCRs, and about 20 million cable converters in cable TV households in the US. Using the Stern findings, this would mean that:

- 90.25 million TVs, 70.6 million VCRs, and 13.1 million cable converters *which are in cable households* reside in fields of 10 millivolts or greater.

- 55.2 million TVs, 43.2 million VCRs, and 11 million cable converters *which are in cable households* reside in fields of 100 millivolts or greater.
- 8.28 million TVs, 6.48 million VCRs, and 1.2 million cable converters *which are in cable households* reside in fields of 1 Volt/ meter or greater.

Consider the CTJ results for irradiated DPU, which shows that for an average of three channels and with the CPE in an average orientation for susceptibility:

- The worst case TV reaches the point of perceptibility at 1.17 mv/m
The worst case VCR at 29.9 mv/m, and
The worst case cable converter at 77.23 mv/m.
- The median TV is perceptible at 51.57 mv/m,
The median VCR at 57.27 mv/m, and
The median cable converter at 292.73 mv/m.
- The very best TV is perceptible at 193.4 mv/m,
The best VCR at 162.73 mv/m, and
The best cable converter at 723.33 mv/m

Superimpose these two lists and the size of the DPU problem begins to emerge. Note that these numbers consider only irradiated co-channel, and not that conducted on the cable braid or on the power cord. The two modes are interrelated, and we have listed the conducted results in the body of the report for reference, but do not list them in the conclusions because the conducted test procedures developed at CTJ have not yet been accepted by all involved consumer manufacturers and the EIA.

In the past, because of the cost of extra outlets, customers have not typically reported all TVs and VCRs in the home as connected to cable. Because of the Cable Act of '92 ruling making extra outlets free of monthly costs, the cable industry has already noted a surge of extra outlets either being connected or admitted to for the first time. It is expected that this trend will continue until virtually all TVs and VCRs found in cable households are connected to cable.

The subject of mitigating factors was mentioned in several earlier paragraphs. These are factors which tend to modify the actual interfering signal level or the exposure of the CPE to such signals. These mitigating factors consists of:

- Ducting - An unusual phenomena in which the transmitted signals are channeled through a building in a non-standard fashion as a function of the building's physical structure.
- Building Attenuation - Considers the shielding properties of the building structure. This is a statistical function which can range from zero to significant attenuation, based on the placement of the CPE in the home and the type of building construction encountered.
- CPE Orientation - As demonstrated in the DPU testing, CPE is usually most susceptible to interference if the radian passing through the tuner of the unit is directed toward the interfering signal source. Other orientations offer some attenuation to the signal.
- Height Above Ground - There is a nominal 20 Log increase in the strength of the interfering signal relative to the height of the CPE above ground level.
- Urban/Suburban Clutter - A factor of the relative juxtaposition of the interfering signal source and the CPE, and the topology of the earth and structures between the two.

The difficulty in applying mitigating factors is that one cannot depend upon achieving a high level of protection over a broad range of installations, or over a long period of time in any one installation, with the results being highly stochastic. The experience of the cable industry is that service calls which are shown to result from DPU most often occur with the introduction of new CPE in the home, or when existing units have been relocated therein. While the activity level of the consumer electronics retailer is pretty much isolated to the time of sale, the cable operator's responsibility for satisfactory service continues from month to month. From the cable standpoint, it matters little whether the DPU problem became apparent with the purchase of new hardware, or at a point years down the road, it still requires a truck roll, the services of a technician, and the installation of a cable converter to fix the problem.

What has become clear during these studies is that adding mitigating factors to the other parameters in an attempt to develop a single performance number for CPE has the effect of dilating the window of acceptability of the test items. As a result of the Cable Act of '92, the FCC has called upon the cable and consumer industries to negotiate a single number which shall represent a limit below which no TV, VCR, or cable converter shall show perceptible DPU interference. This implies that a statistical process, which represents a range of performances based on both controlled (such as CPE design and construction) and uncontrolled (such as mitigating factors) issues, must be reduced to a single number, below which the performance range cannot extend. Considering the Stern data, it would appear that a 95% solution to the problem will fall into the 1.0 volt/meter range.

Unlike the DPU findings above, we published the results of the receiver performance tests more as a benchmark to determine the current state-of-art for both consumer and cable grade hardware, and primarily to assist in the completion of the engineering labor supporting the IS-23 effort in the JEC. As mentioned earlier, the test facility drawings and procedures used in these tests have all been forwarded to the membership of the JEC for analysis and comment. There will no doubt be changes suggested for these tests, all of which will be included where appropriate. Considerable non-trivial variations on the individual test plans, procedures, and facilities were tried at CTJ with the differences in results varying little more than 2.0 dB. This leads us to have confidence in these procedures as to their accuracy in portraying the performance parameter tested. However,

since others may derive procedures which are either easier or cheaper to implement, or for any other legitimate reason may show increased promise, all constructive comments will be considered, tested, and implemented or rejected based on merit in the eyes of the JEC.

What is clear from these performance measurements, is that all CPE could bear some improvements in several of the eight areas considered. Among TVs and VCRs the problems measured here result almost exclusively from the use of designs which are optimized for off-air reception and are not appropriate for the different delivery conditions encountered when connected to a cable system. Since cable cannot regress to simulate the conditions found in the broadcast environment without losing its advantages and its very reason for existence, improvements can only be found in adapting the terminal devices, the CPE, to the delivery system. This is precisely what has occurred in all other areas of telecommunications, including wire and RF telephony, LANs, MANs, business satellite systems, microwave delivery systems, and in home DBS terminal equipment.

As we now stand on the threshold of the era of digital television transmission, tests performed at the Advanced Television Test Center, by CableLabs, and at other facilities underlines the fact that all receivers must be improved in all eight of the above factors, plus several more, including phase noise, group delay, and residual FM, if the transitional hybrid CPE currently being planned by the consumer manufacturers is to be usable through its expected lifetime.